

## SHU670X 60CM UNDERMOUNT RANGEHOOD

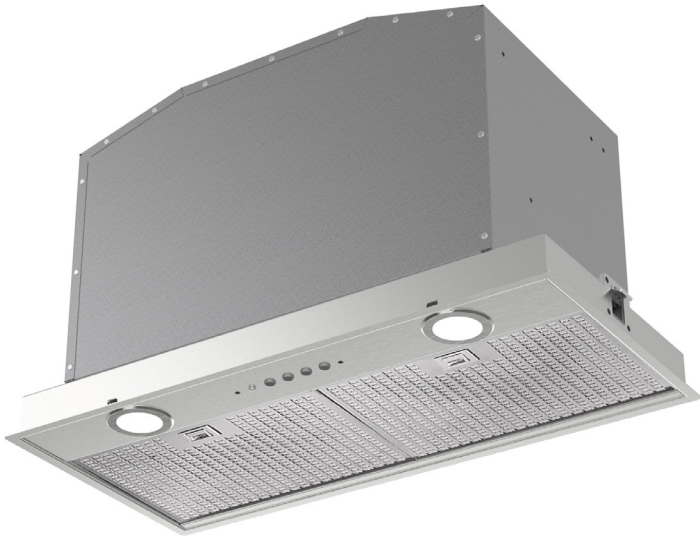

EAN 9345025001498

Finish	Stainless steel
Dimensions	600mmW x 339mmH x 290mmD
Installation	Undermount
Motor	1 x 250W
Max Airflow	690m <sup>3</sup> /hr (IEC 61591)
Noise rating	50-67 dBA (IEC 60704-3)
Illumination	2 x 1W LED
Speeds	Three
Delay stop	No
Supplied Accessories	2 x stainless steel grease filters
Optional Accessories	None
Ducting Options	Duct to atmosphere / recirculate - 150mm diameter ducting required
Power	220-240V 50/60Hz 10A
Warranty	Two years parts and labour

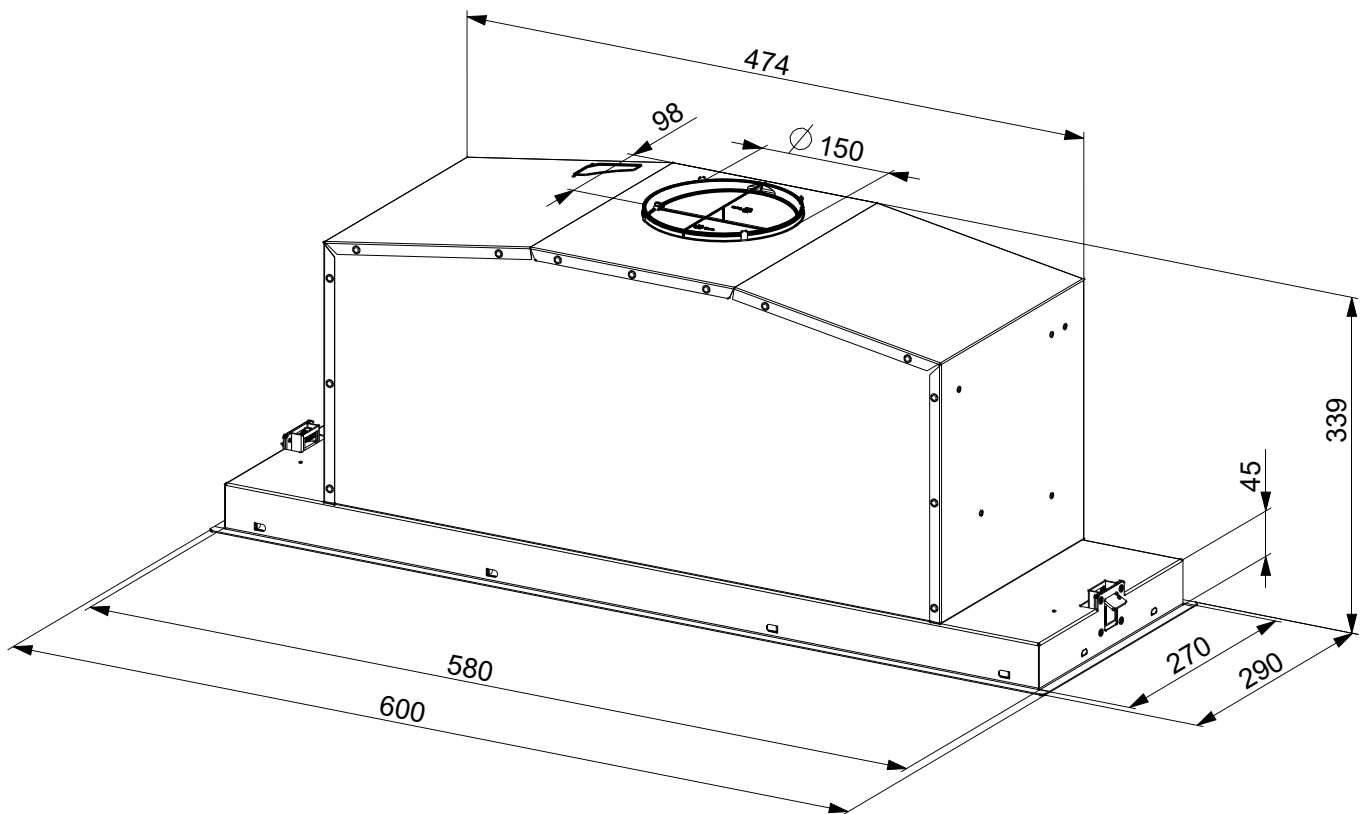

PLEASE NOTE: drawings are not to scale. They are to assist only.

WARNING: technical specifications and product sizes can be varied by the manufacturer without notice.

Cutouts for appliances should only be by physical product measurements. The above information is indicative only.

ID160812