

USER GUIDE & INSTALLATION INSTRUCTIONS

Nexus 90 Dual Fuel

Australia

U110621-02

SLOW BAKED LEG OF LAMB



INGREDIENTS

- 2-3 large sprigs of rosemary
- 4 large garlic cloves cut in half lengthways
- 1.8 kg leg of lamb
- 8 good quality anchovy fillets, halved
- 100 ml olive oil
- 250 ml dry red wine
- Maldon salt and freshly ground black pepper

METHOD

1. Preheat the oven to 220°C (for a conventional oven), 200°C (for a fan oven) or gas mark 7.
2. Pull the small sprigs off the rosemary branches and set aside with the garlic.
3. Using the tip of a paring knife, make up to 20 well-spaced cuts into the flesh of the lamb, about 2.5 cm inch deep. Divide the rosemary sprigs, garlic and anchovies and push down into the cuts. Place the leg on a large roasting tin and pour over the oil, massaging it all over the joint. Season well with salt and pepper and pour the wine and 250 ml water into the tin.
4. Put into the oven and sear for 15 minutes, then turn the temperature right down to 130°C (conventional oven), 110°C (fan oven) or gas mark 1 and roast for 4-5 hours, basting every 30 minutes or so. Basting frequently helps to keep the meat moist and encourages the build up of a good glaze on the outside. Add more liquid (wine or water) if the tin looks dry and there should always be liquid in the tin throughout this cooking process.
5. The meat is ready when it starts to fall off the bone, at which point it should have a core temperature of 90°C. Remove from the oven, transfer to a warmed carving dish, cover loosely with foil and leave to rest in a warm place for 30-45 minutes before carving.
6. Pour the juices from the tin into a tall hi-ball glass and allow to settle. Spoon the fat from the top of the glass. There should be enough sticky, reduced juices for an intense gravy. If not, pour the juices you have back into the roasting tin and put it over the heat, pour in a splash of water or wine and deglaze the tin scraping up all the sticky bits from the base. Boil fast until syrupy, taste and correct the seasoning.

RASPBERRY SOUFFLÉ



INGREDIENTS

- 400 g raspberries
- 1 tbsp lemon juice
- 100 g caster sugar
- 2 tsp crème de framboise
- 1 tsp cornflour
- 180 g egg whites (about 6)
- Pinch of cream of tartar or a squeeze of lemon juice
- Icing sugar for dusting

METHOD

1. For the soufflé, press the raspberries through a fine sieve to produce 180 g of purée. Put this into a heavy-bottomed pan, add the lemon juice and reduce down to a thick jam, stirring from time to time and being careful not to let it catch and burn.
2. Put 45 g of the sugar in a separate pan. Melt it and then boil until it becomes a thick syrup (121°C on a sugar thermometer). To test without a thermometer, dip a teaspoon into the syrup and then dip quickly into cold water. You should be able to roll the cooling syrup into a ball between your fingers. Be careful as the syrup is extremely hot. When it has reached the right point, stir the hot syrup into the raspberry jam.
3. Mix the framboise and cornflour together and stir into the jam over the heat. Turn the jam into a small bowl, sprinkle the surface with icing sugar and cover with cling film.
4. Preheat the oven (not grill) to 180°C shelf level 2 (conventional oven), 160°C (fan oven) or gas mark 4 centre shelf.
5. Whisk the egg whites with the cream of tartar until you can form soft peaks, then fold in the remaining caster sugar. Lightly fold the whites into the jam, leaving thin traces of white visible in the mixture.
6. Spoon into four large buttered and sugared ramekins, place these on a baking tray and bake for 10 minutes.
7. Dust with icing sugar.

Contents

1. Before You Start...	1	6. Troubleshooting	21
Personal Safety	1		
Electrical Connection Safety	2	7. Installation	23
Gas Connection Safety	2	Service and Spares	23
If You Smell Gas	2	Safety Requirements and Regulations	24
Peculiar Smells	2	Provision of Ventilation	24
Ventilation	2	Location of Cooker	24
Oven Care	3	Conversion	24
Hob Care	4	Positioning the Cooker	26
Grill/Glide-out Grill™ Care	4	Moving the Cooker	27
Cooling Fan	4	Fitting the Stability Bracket or Chain	28
Cooker Care	4	Repositioning the Cooker Following Connection	28
Cleaning	4	Gas Connection	29
		Electrical Connection	30
2. Cooker Overview	5	8. Final Fitting	32
Hotplate Burners	5	Final Checks	32
Wok Burner	6	Final Fitting	32
The Wok Cradle	6	Customer Care	32
The Griddle	7		
The Glide-out Grill™	8	9. Conversion to LP Gas	33
The Ovens	9	Conversion from Natural Gas (1.0 kPa) to LPG X Propane (2.54 kPa)	33
Using the Clock	12	Injectors	33
Accessories	14	Tap Adjustment	33
Oven Light	14	Set the Governor	34
		Pressure Testing	34
3. Cooking Tips	15	Affix Label	34
Tips on Cooking with the Timer	15	10. Servicing	35
General Oven Tips	15		
4. Cooking Table	16	11. Circuit Diagram	41
5. Cleaning Your Cooker	17	12. Technical Data	42
Essential Information	17	Pressures	42
Hotplate Burners	17	Dimensions	42
Grills	18	Hotplate Ratings	42
Control Panel and Doors	18	Hotplate Efficiency	43
Ovens	19	Oven Data	44
The Tall Oven	19		
Cleaning Table	20		

1. Before You Start...

Your cooker should give you many years of trouble-free cooking if installed and operated correctly. It is important that you read this section before you start.

Personal Safety

This appliance is for cooking purposes only. It must not be used for other purposes, for example heating a room. Using it for any other purpose could invalidate any warranty or liability claim. Besides invalidating claims this wastes fuel and may overheat the control knobs.

This cooker must be installed in accordance with the relevant instructions in this booklet and with the national and local regulations as well as the local gas and electricity supply companies' requirements.

- This appliance can be used by children aged from 8 years and above and persons with reduced physical, sensory or mental capabilities or lack of experience and knowledge if they have been given supervision or instruction concerning use of the appliance in a safe way and understand the hazards involved.
- Children **less** than 8 years of age should be kept away unless continuously supervised. Children shall not play with the appliance.
- This appliance is designed for domestic cooking only. Use for any other purpose could invalidate any warranty or liability claim.
- The appliance and its accessible parts become hot during use and will retain heat even after you have stopped cooking. Care should be taken to avoid touching heating elements.
- A long term cooking process has to be supervised from time to time. A short term cooking process has to be supervised continuously.
- At the risk of fire **DO NOT** store items on the cooking surfaces.
- To avoid overheating, **DO NOT** install the cooker behind a decorative door.
- Accessible parts will become hot during use and will retain heat even after you have stopped cooking. Keep babies and children away from the cooker and never wear loose-fitting or hanging clothes when using the appliance.
- **DO NOT** use a steam cleaner on your cooker.
- Always keep combustible materials, e.g. curtains, and flammable liquids a safe distance away from the cooker.
- **DO NOT** spray aerosols in the vicinity of the cooker while it is on.

Electrical Connection Safety

A qualified service engineer should service the cooker and only approved spare parts should be used.

All installations must be in accordance with the relevant instructions in this booklet, with the relevant national and local regulations and with the local electricity supply companies' requirements.

Read the instructions before installing or using this appliance.

- This appliance is heavy so take care when moving it.
- The cooker may be installed in a kitchen/kitchen diner but **NOT** in a room containing a bath or shower.
- This cooker must be earthed.
- This cooker **MUST NOT** be connected to an ordinary domestic power point.
- It is normal for the hob control display to flash for about 2 seconds during first power setting. Set the clock to make sure that the oven is functional – see the relevant section in this manual.
- The appliance must be installed in accordance with the regulations in force and only in a well ventilated space.
- Failure to install the appliance correctly could invalidate any warranty or liability claims and lead to prosecution.
- **DO NOT** install the appliance on a platform.
- **TURN OFF** the electricity supply before moving the cooker
- Disconnect from the electricity and gas supply before servicing.
- Before restoring the electricity supply, check that the appliance is electrically safe.

Gas Connection Safety

- This cooker is a Class 2 Subclass 1 appliance.
- This appliance can be converted for use on another gas.
- Before installation, make sure that the cooker is suitable for your gas type and supply voltage. See the data badge.
- **DO NOT** use reconditioned or unauthorised gas controls.
- Disconnect from the electricity and gas supply before servicing.
- When servicing or replacing gas-carrying components disconnect from the gas supply before starting operation. Check the appliance is gas sound after completion.
- Make sure that the gas supply is turned on and that the cooker is wired in and switched on.
- In your own interest and that of safety, it is law that all gas appliances be installed by a qualified person(s).
- An appliance for use on LPG must not be installed in a room or internal space below ground level, e.g. in a basement.

If You Smell Gas

- **DO NOT** turn electric switches on or off
- **DO NOT** smoke
- **DO NOT** use naked flames
- Turn off the gas at the meter or cylinder
- Open doors and windows to get rid of the gas
- Keep people away from the area affected
- Call your gas supplier

Peculiar Smells

When you first use your cooker it may give off an odour. This should stop after use.

Before using for the first time, make sure that all packing materials have been removed and then, to dispel manufacturing odours, turn the ovens to 200°C and run for at least an hour.

Before using the grill for the first time you should also turn on the grill and run for **30** minutes with the grill pan in position, pushed fully back and the grill door open.

Make sure the room is well ventilated to the outside air (see 'Ventilation' below). People with respiratory or allergy problems should vacate the area for this brief period.

Ventilation

The use of a cooking appliance results in the production of heat and moisture in the room in which it is installed. Therefore, make sure that the kitchen is well ventilated: keep natural ventilation holes open or install a powered cookerhood that vents outside. If you have several hotplates/ burners on, or use the cooker for a long time, open a window or turn on an extractor fan

Maintenance

- It is recommended that this appliance is serviced annually.
- **DO NOT** use cooking vessels on the hotplate that overlap the edges.
- Unless specified otherwise in this guide, always allow the cooker to cool and then switch it off at the mains before cleaning or carrying out any maintenance work.
- **DO NOT** attempt to disassemble or clean around any burner while another burner is on, otherwise an electric shock could result.
- **NEVER** operate the cooker with wet hands.
- **DO NOT** use a towel or other bulky cloth in place of a glove – it might catch fire if brought into contact with a hot surface.
- **DO NOT** use hotplate protectors, foil or hotplate covers of any description. These may affect the safe use of your hotplate burners and are potentially hazardous to health.
- **NEVER** heat unopened food containers. Pressure build up may make the containers burst and cause injury.
- **DO NOT** use unstable saucepans. Always make sure that you position the handles away from the edge of the hotplate.
- **NEVER** leave the hotplate unattended at high heat settings. Pans boiling over can cause smoking, and greasy spills may catch on fire. Use a deep fat thermometer whenever possible to prevent fat overheating beyond the smoking point.
- Unattended cooking on a hob with fat or oil can be dangerous and may result in fire.
- **NEVER** leave a chip pan unattended. Always heat fat slowly, and watch as it heats. Deep fry pans should be only one third full of fat.
- **NEVER** try to move a pan of hot fat, especially a deep fat fryer. Wait until the fat is cool. Filling the pan too full of fat can cause spill over when food is added. If you use a combination of oils or fats in frying, stir them together before heating, or as the fats melt.
- Foods for frying should be as dry as possible. Frost on frozen foods or moisture on fresh foods can cause hot fat to bubble up and over the sides of the pan. Carefully watch for spills or overheating of foods when frying at high or medium high temperatures.
- **DO NOT** use the top of the flue (the slot along the back of the cooker) for warming plates, dishes, drying tea towels or softening butter.
- **DO NOT** use water on grease fires and never pick up a flaming pan. Turn the controls off and then smother a flaming pan on a surface unit by covering the pan completely with a well fitting lid or baking tray. If available, use a multi-purpose dry chemical or foam-type fire extinguisher.
- **DO NOT** modify this appliance. This appliance is not intended to be operated by means of external timer or separated remote-control system.
- Flammable materials may explode and result in fire or property damage.

Oven Care

- When the oven is not in use and before attempting to clean the cooker always be certain that the control knobs are in the **OFF** position.
- Use oven gloves to protect your hand from potential burns.
- Cooking high moisture content foods can create a 'steam burst' when the oven door is opened (**Fig. 1.1**). When opening the oven, stand well back and allow any steam to disperse.
- The inside door face is constructed with toughened safety glass. Take care **NOT** to scratch the surface when cleaning the glass panel.
- Accidental damage may cause the door glass panel to fracture.
- Keep oven vent ducts unobstructed.
- **DO NOT** use harsh abrasive cleaners or sharp metal scrapers to clean the oven door glass since they can scratch the surface, which may result in shattering of the glass.
- Make sure the shelves are pushed firmly to the back of the oven. **DO NOT** close the door against the oven shelves.
- **DO NOT** use aluminium foil to cover shelves, linings or the oven roof.
- When the oven is on, **DO NOT** leave the oven door open for longer than necessary, otherwise the control knobs may become very hot.
- **DO NOT** use the timed oven if the adjoining oven is already warm.
- **DO NOT** place warm food in the oven to be timed.
- **DO NOT** use a timed oven that is already warm.
- Use dry oven gloves when applicable – using damp gloves might result in steam burns when you touch a hot surface.

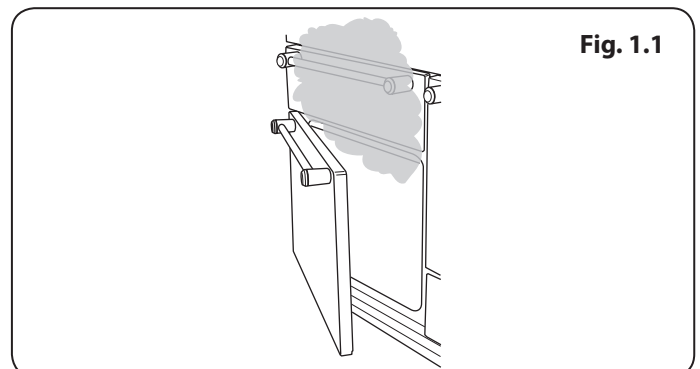

Fig. 1.1

Hob Care

- **NEVER** allow anyone to climb or stand on the hob.
- **DO NOT** use the hob surface as a cutting board.
- **DO NOT** leave utensils, foodstuffs or combustible items on the hob when it is not in use (e.g. tea towels, frying pans containing oil).
- **DO NOT** place plastic or aluminium foil, or plastic containers on the hob.
- Always turn the control to the **OFF** position before removing a pan.
- Avoid heating an empty pan. Doing so may damage both the hob and pan.

Grill/Glide-out Grill™ Care

- When using the grill, make sure that the grill pan is in position and pushed fully in, otherwise the control knobs may become very hot.
- **DO NOT** leave the grill on for more than a few moments without the grill pan underneath it, otherwise the knobs may become hot.
- **NEVER** close the grill door when the grill is on.
- Accessible parts may be hot when the grill is in use. Young children should be kept away.

Cooling Fan

This appliance may have a cooling fan. When the grill or oven is in operation the fan will run to cool the fascia and control knobs.

Cooker Care

As steam can condense to water droplets on the cool outer trim of the oven, it may be necessary during cooking to wipe away any moisture with a soft cloth. This will also help to prevent soiling and discolouration of the oven exterior by cooking vapours.

Cleaning

- Isolate the electricity supply before carrying out any thorough cleaning. Allow the cooker to cool.
- In the interests of hygiene and safety, the cooker should be kept clean at all times as a build up in fats and other food stuff could result in a fire.
- Clean only the parts listed in this guide.
- Clean with caution. If a wet sponge or cloth is used to wipe spills on a hot surface, be careful to avoid steam burns. Some cleaners can produce noxious fumes if applied to a hot surface.
- **NEVER** use paint solvents, washing soda, caustic cleaners, biological powders, bleach, chlorine based bleach cleaners, coarse abrasives or salt.
- **DO NOT** mix different cleaning products – they may react together with hazardous results.
- All parts of the cooker can be cleaned with hot soapy water.
- Take care that no water seeps into the appliance.
- Before you remove any of the grill parts for cleaning, make sure that they are cool or use oven gloves.
- **DO NOT** use any abrasive substances on the grill and grill parts.
- **DO NOT** put the side runners in a dishwasher.
- **DO NOT** put the burner heads in a dishwasher.
- **NEVER** use caustic or abrasive cleaners as these will damage the surface.
- **DO NOT** use steel wool, oven cleaning pads or any other materials that will scratch the surface.
- **NEVER** store flammable materials in the drawer. This includes paper, plastic and cloth items, such as cookbooks, plastic ware and towels, as well as flammable liquids.
- **DO NOT** store explosives, such as aerosol cans, on or near the appliance.
- **DO NOT** use steel wool, oven cleaning pads, or any other materials that will scratch the surface.
- **DO NOT** attempt to disassemble or clean around any burner while another burner is on, otherwise an electric shock could result.

2. Cooker Overview



The 90 dual fuel cooker (**Fig. 2.1**) has the following features:

- A.** 4 hotplate burners and a Wok Burner
- B.** Control Panel
- C.** Glide-out Grill™ with 4 position Trivet
- D.** Multifunction Oven
- E.** Fan Oven

Hotplate Burners

The labels by each of the control knobs indicates which area that knob controls.

Each burner has a Flame Supervision Device (FSD) that prevents the flow of gas if the flame goes out.

When a hotplate control knob is pressed in, sparks will be made at every burner – this is normal. Do not attempt to disassemble or clean around any burner while another burner is on, otherwise an electric shock could result.

To light a burner, push in and turn the associated control knob to the high position as indicated by the large flame symbol (🔥), (**Fig. 2.2**).

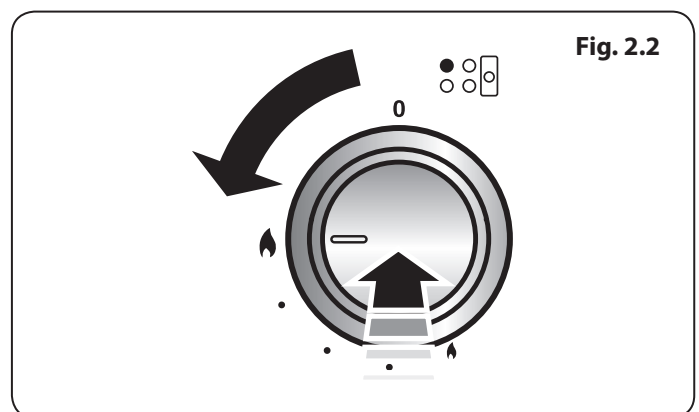

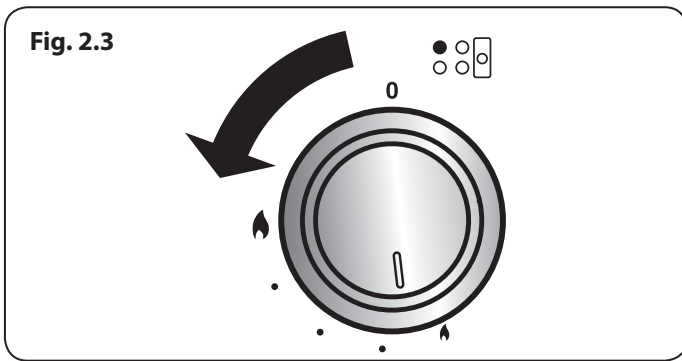

The igniter should spark and light the gas. Continue to press in the knob to let the gas through to the burner for about ten seconds.

If and when you let go of the control knob or the burner goes out, then the FSD has not been bypassed. Turn the control knob to the OFF position and wait for one minute before you try again, this time making sure to hold in the control knob for slightly longer.

Adjust the flame height to suit by turning the knob counter-clockwise (**Fig. 2.3**). On this cooker the low position is beyond high, **NOT** between high and off.

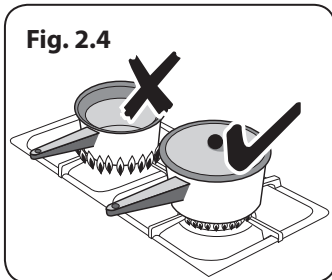

If a burner flame goes out, turn off the control knob and leave it for one minute before relighting it.

Make sure that the flames are under the pans. Using a lid will help the contents boil more quickly (**Fig. 2.4**).

Large pans should be spaced well apart.

Pans and kettles with concave bases or down-turned base rims should not be used (**Fig. 2.5**).

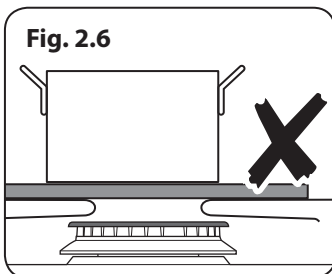
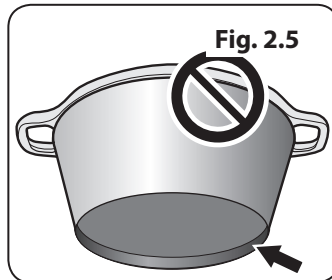

Simmering aids, such as asbestos or mesh mats, are **NOT** recommended (**Fig. 2.6**). They will reduce burner performance and could damage the pan supports.

You should also avoid using unstable and misshapen pans that may tilt easily, and pans with a very small base diameter, e.g. milk pans, single egg poachers (**Fig. 2.7**).

The minimum recommended pan diameter is 120 mm. The maximum allowable pan base diameter is 260 mm.

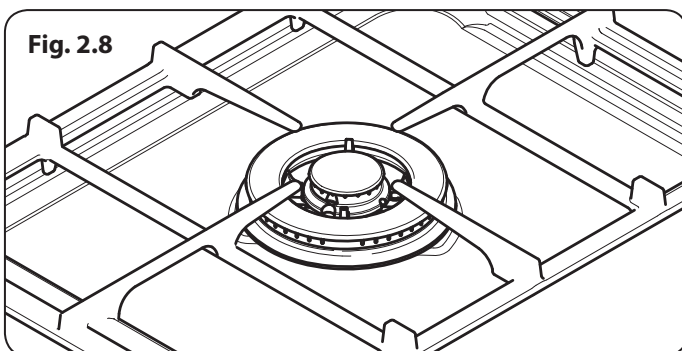
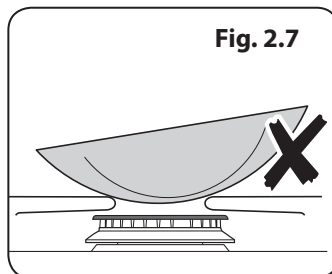

DO NOT use cooking vessels on the hotplate that overlap the edges.

Wok Burner

The Wok Burner is designed to provide even heat over a large area. It is ideal for large pans and stir-frying (**Fig. 2.8**).

For heating smaller pans, the aforementioned hotplate burners may be more efficient.

You should wipe the enamel top surface of the cooker around the hotplate burners as soon as possible after spills occur. Try to wipe them off while the enamel is still warm.

Note: The use of aluminium pans may cause metallic marking of the pan supports. This does not affect the durability of the enamel and may be cleaned off with a suitable metal cleaner.

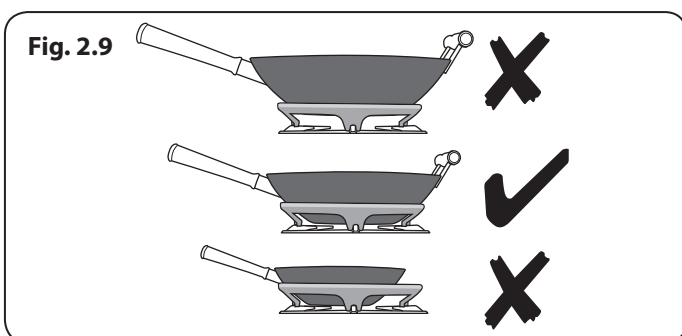

The Wok Cradle

The Wok Cradle is designed to fit a 35 cm wok. If you use a different wok, make sure that it fits the cradle. Woks vary very widely in size and shape. It is important that the wok sits down on the pan support – however, if the wok is too small, the cradle will not support it properly (**Fig. 2.8**).

The cradle should be used on the wok burners only. When you fit the cradle, check that it is supported properly on a pan support and that the wok is sitting level in the cradle (**Fig. 2.10**).

The cradle will get very hot in use – allow plenty of time for it to cool before you pick it up.

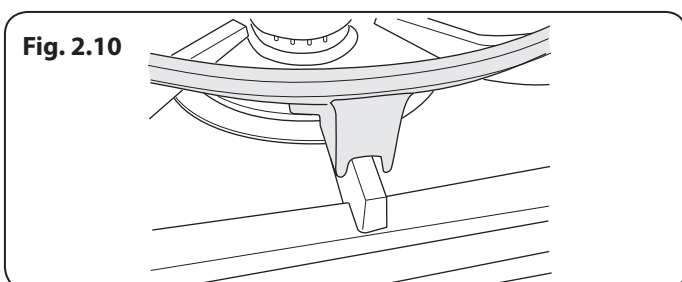

The Griddle

The griddle fits the left-hand pan support, front to back (**Fig. 2.11**). It is designed for cooking food on directly. **DO NOT** use pans of any kind on it. The griddle surface is non-stick and metal cooking utensils (e.g. spatulas) will damage the surface. Use heat resistant plastic or wooden utensils.

⚠ DO NOT put it crossways – it will not fit properly and will be unstable (Fig. 2.12).

⚠ DO NOT put it on any other burner – it is not designed to fit in any of the other pan supports.

Position the griddle over the hotplate burners resting on the pan support. Check that it is securely located.

The griddle can be lightly brushed with cooking oil before use (**Fig. 2.13**). Light the hotplate burners. Adjust the flame heights to suit.

Preheat the griddle for **a maximum of 5 minutes** before adding food. Leaving it longer may cause damage. Turn the control knobs towards the low position, marked with the small flame symbol, to reduce the burner flames.

⚠ Always leave space around the griddle for the gases to escape.

⚠ NEVER fit two griddles side by side (Fig. 2.14).

After cooking, allow the griddle to cool before cleaning.

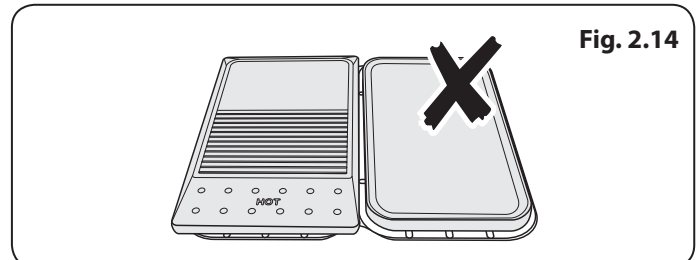
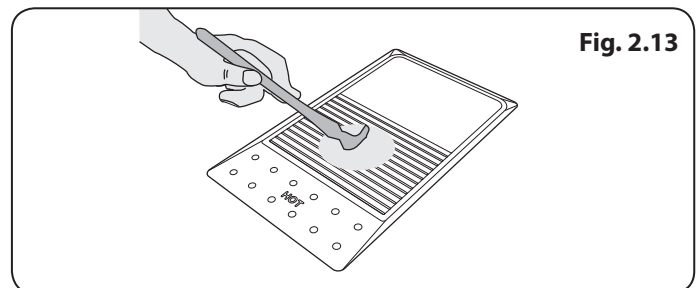
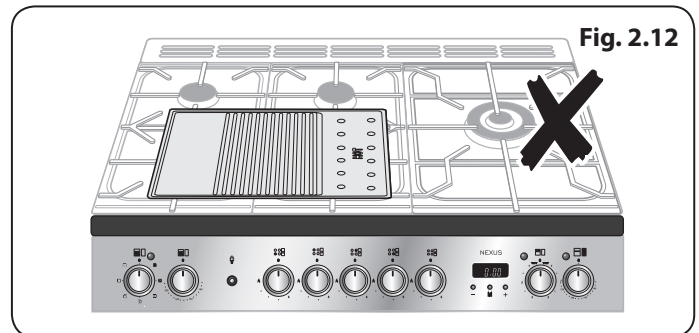
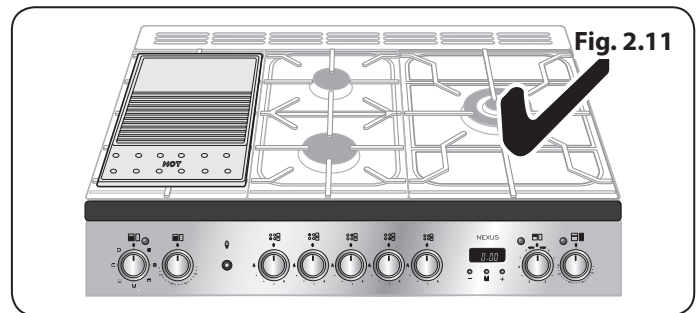

Fig. 2.15

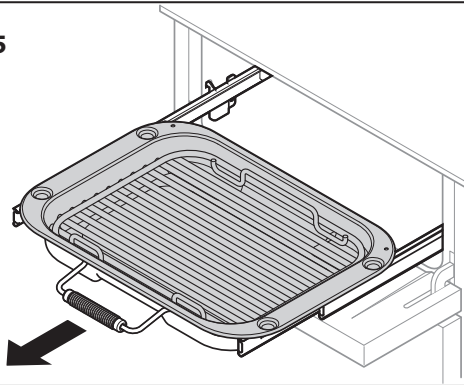

Fig. 2.16

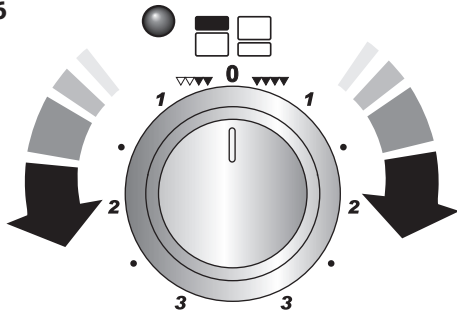
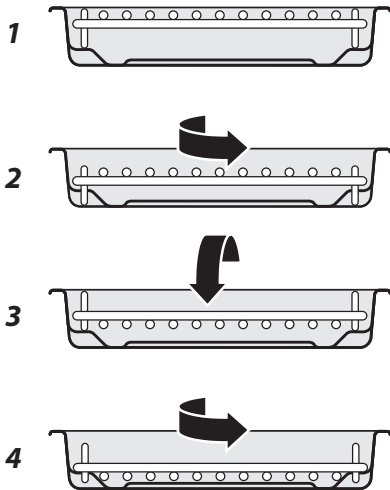

Fig. 2.17



The Glide-out Grill™

Open the door and pull the grill pan carriage forward using the handle (Fig. 2.15).

The grill has two elements that allow either the whole area of the pan to be heated or just the right-hand half.

Adjust the heat to suit by turning the control knob. To heat the whole grill, turn the knob clockwise (Fig. 2.16).

To heat the right-hand half, turn the knob counter-clockwise. The neon indicator light by the grill control will come on.

For best results, slide the carriage back into the grill chamber and preheat the appropriate part(s) of the grill for two minutes. The grill trivet can be removed and the food placed on it while you are waiting for the grill to preheat.

⚠ DO NOT leave the grill on for more than a few moments without the grill pan underneath it, otherwise the knobs may become hot.

Once the grill has preheated, slide the carriage out again. With the trivet back in place with the food on it, slide the carriage back into the grill chamber. Make sure that it is pushed right in.

⚠ CAUTION: Accessible parts may be hot when the grill is in use. Young children should be kept away.

The grill pan trivet can be set to four different grilling heights by a combination of turning it back to front and turning it upside down (Fig. 2.17).

Do not leave the grill on for more than a few moments, without the grill pan underneath it.

⚠ Never close the grill door when the grill is on.

⚠ CAUTION: This appliance is for cooking purposes only. It must not be used for other purposes, for example room heating.

The Ovens

The clock must be set to the time of day before the left hand oven will work. See the following section on 'The Clock' for instructions on setting the time of day.

References to 'left-hand' and 'right-hand' ovens apply as viewed from the front of the appliance.

The left-hand oven is a multifunction oven, while the right-hand oven is a fan oven.

The Multifunction Oven

As well as the oven fan and fan element, multifunction ovens are fitted with two extra heating elements, one visible in the top of the oven and the second under the oven base. Take care to avoid touching the top element and element deflector when placing or removing items from the ovens.

The multifunction oven has 3 main cooking functions: **fan**, **fan assisted** and **conventional cooking**. These functions should be used to complete most of your cooking.

The **browning element** and **base heat** can be used in the latter part of the cooking process to fine tune the results to your particular requirements.

Use **fanned grilling** for all your grilling needs and **defrost** to safely thaw small items of frozen food.

Table 2.1 gives a summary of the multifunction modes.

The multifunction ovens have many varied uses. We suggest you keep a careful eye on your cooking until you are familiar with each function. Remember – not all functions will be suitable for all food types.

Please remember that all cookers vary – temperatures in your new ovens may differ to those in your previous cooker.

Function	Use
Defrost	To thaw small items in the oven without heat
Fan oven	A full cooking function, even heat throughout, great for baking
Fanned grilling	Grilling meat and fish with the door closed
Fan assisted	A full cooking function good for roasting and baking
Conventional oven	A full cooking function for roasting and baking in the lower half of the oven
Browning element	To brown and crisp cheese topped dishes
Base heat	To crisp up the bases of quiche, pizza or pastry

Table 2.1

Multifunction Oven Functions

Defrost



This function operates the fan to circulate cold air only. Make sure the temperature control is at 0°C and that no heat is applied. This enables small items such as desserts, cream cakes and pieces of meat, fish and poultry to be defrosted.

Defrosting in this way speeds up the process and protects the food from flies. Pieces of meat, fish and poultry should be placed on a trivet, over a tray to catch any drips. Be sure to wash the trivet and tray after defrosting.

Defrost with the oven door closed.

Large items, such as whole chickens and joints should not be defrosted in this way. We recommend this be carried out in a refrigerator.

Defrosting should not be carried out in a warm oven or when an adjoining oven is in use or still warm.

Make sure that dairy foods, meat and poultry are completely defrosted before cooking.

Fan Oven



This function operates the fan and the heating element around it. An even heat is produced throughout the oven, allowing you to cook large amounts quickly.

Fan oven cooking is particularly suitable for baking on several shelves at one time and is a good 'all-round' function. It may be necessary to reduce the temperature by approximately 10°C for recipes previously cooked in a conventional oven.

If you wish to preheat the oven, wait until the indicator light has gone out before inserting the food.

Fanned Grilling



This function operates the fan whilst the top element is on. It produces a more even, less fierce heat than a conventional grill. For best results, place the food to be grilled on a trivet over a roasting tin, which should be smaller than a conventional grill pan. This allows greater air circulation. Thick pieces of meat or fish are ideal for grilling in this way, as the circulated air reduces the fierceness of the heat from the grill.

The oven door should be kept closed while grilling is in progress, so saving energy. You will also find that the food needs to be watched and turned less than for normal grilling. Preheat this function before cooking.

For best results we recommend that the grill pan is not located on the uppermost shelf.

Fan Assisted Oven



This function operates the fan, circulating air heated by the elements at the top and the base of the oven. The combination of fan and conventional cooking (top and base heat) makes this function ideal for cooking large items that need thorough cooking, such as a large meat roast.

It is also possible to bake on two shelves at one time, although they will need to be swapped over during the cooking time, as the heat at the top of the oven is greater than at the base, when using this function.

This is a fast intensive form of cooking; keep an eye on the food cooking until you have become accustomed to this function.

Conventional Oven (Top and Base Heat)



This function combines the heat from the top and base elements. It is particularly suitable for roasting and baking pastry, cakes and biscuits.

Food cooked on the top shelf will brown and crisp faster than on the lower shelf, because the heat is greater at the top of the oven than at the base, as in 'Fan Assisted Oven' function. Similar items being cooked will need to be swapped around for even cooking. This means that foods requiring different temperatures can be cooked together, using the cooler zone in the lower half of the oven and hotter area to the top.

The exposed top element may cook some foods too quickly, so we recommend that the food be positioned in the lower half of the oven to cook. The oven temperature may also need to be lowered.

Browning Element



This function uses the element in the top of the oven only. It is a useful function for the browning or finishing of pasta dishes, vegetables in sauce, shepherds pie and lasagne, the item to be browned being already hot before switching to the top element.

Base Heat



This function uses the base element only. It will crisp up your pizza or quiche base or finish off cooking the base of a pastry case on a lower shelf. It is also a gentle heat, good for slow cooking of casseroles in the middle of the oven or for plate warming.

The Browning and Base Heat functions are useful additions to your oven, giving you flexibility to finish off items to perfection.

Fan Oven

The right-hand oven is a fan oven that circulates hot air continuously, which means faster, more even cooking.

The recommended cooking temperatures for a fan oven are generally lower than a conventional oven.

Note: Please remember that all cookers vary so temperatures in your new ovens may differ to those in your previous cooker.

Operating the Ovens

Operating the Multifunction Oven

The multifunction oven has two controls: a function selector and a temperature setting knob (**Fig. 2.18**).

Turn the function selector control to a cooking function. Turn the oven temperature knob to the temperature required (**Fig. 2.18**).

The oven heating light will glow until the oven has reached the temperature you selected (**Fig. 2.20**). It will then cycle on and off during cooking as the oven maintains the selected temperature.

Operating the Fan Oven

Turn the oven knob to the desired temperature (**Fig. 2.19**).

The oven indicator light will glow until the oven has reached the temperature selected (**Fig. 2.20**). It will then cycle on and off during cooking.

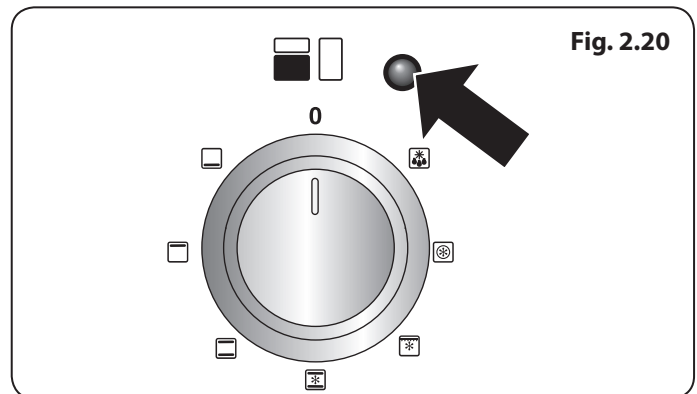
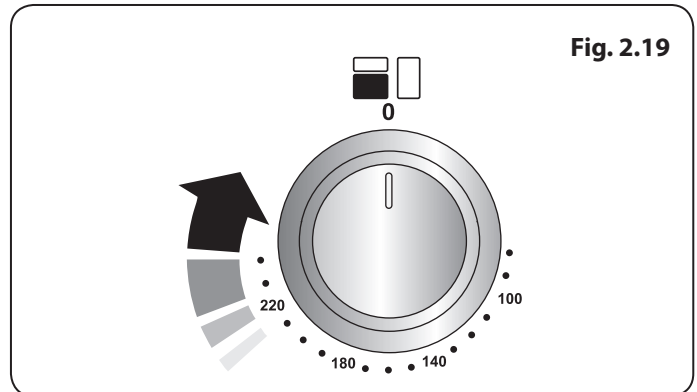
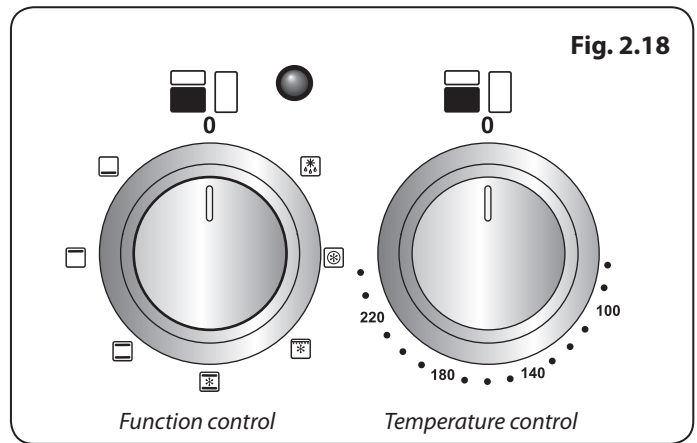

Fig. 2.21

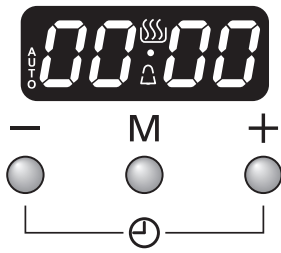

Fig. 2.22

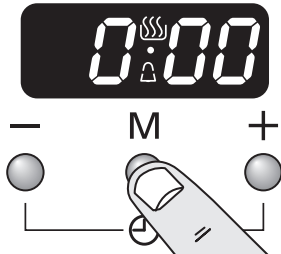
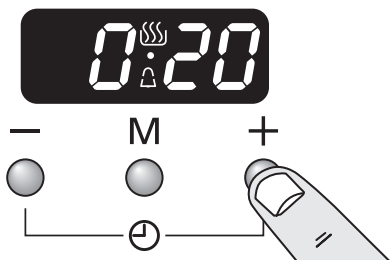

Fig. 2.23



TOP TIP

By pressing the mode [M] whilst **Minute Minder** is counting down, it is possible to see time remaining or adjust the countdown time using the [+] or [-] buttons.

Fig. 2.24

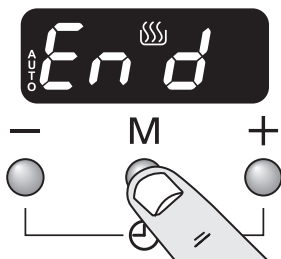

Fig. 2.25

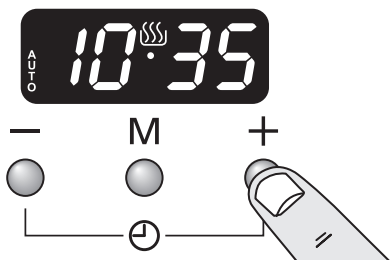
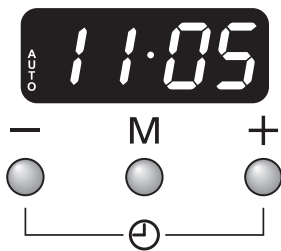

Fig. 2.26



Using the Clock

You can use the clock to turn the left-hand oven on and off.

Note: When using the timer functions, first set the clock as required before setting the oven temperature.

The oven can be switched on when the cook symbol [🔥] is displayed.

Setting the Clock

1. The LCD clock is shown in (Fig. 2.21). Once the cooker is connected and switched on, the display flashes (00:00) and the time starts from (00:00).
2. To set the clock press the [+] and [-] buttons simultaneously, the point between hours and minutes will start to flash for 5 seconds. Whilst the point is flashing press either the [+] or [-] button to set the correct time.

IMPORTANT: The timed oven will not operate unless the clock has been set.

Program Selection - Setting the Minute Minder

The minute minder [🔔] provides the ability to set a countdown from 00:01h to 23:59h, at the end of which an alarm will sound.

1. Press the mode [M] button once (Fig. 2.22). The bell symbol (🔔) will flash on the display. Select the desired countdown from 00:01h to 23:59h using the [+] button (Fig. 2.23). The countdown will automatically begin and the (🔔) symbol will show in the display.
2. Once the specified time has elapsed an alarm will sound.
3. To stop the alarm press any button.

Re-set the Minute Minder

To re-set the minute minder, first select the minute minder program by pressing the mode [M] button. Then press the [+] and [-] buttons simultaneously.

- The 'cook period', which is the length of time you want the oven to cook for (dur).
- The 'stop time', which is the time of day you want the oven to stop cooking (End).

To Stop the left-hand Oven at a Specific Time of Day

1. Press the mode [M] button 3 times, until the display flashes (End) (Fig. 2.24).
2. Select the 'stop time' using the [+] or [-] buttons. The display will show the current time along with the AUTO and Cooking symbols (Fig. 2.25).
3. When the 'stop time' is reached an alarm will sound and the oven will stop working. The word AUTO will flash on the display (Fig. 2.26).
4. Press any button to stop the alarm and return to manual cooking. If the alarm is not stopped, it will stop automatically after 7 minutes.

To Start and Then Stop the Left-hand Oven

Set the left-hand oven to automatically start and stop using a combination of the 'cook period' and 'stop time'.

You cannot set a start time directly – this is set automatically by a combination of the 'cook period' and 'stop time'.

1. Press the mode [M] button until the display flashes (dur) (**Fig. 2.27**). Then set the 'cook period' using the [+] or [-] buttons.
2. Press the mode [M] button until the display flashes (End) (**Fig. 2.28**). Then set the 'stop time' using the [+] or [-] buttons. Current time will be displayed along with the word 'AUTO' (**Fig. 2.29**).
3. Set the oven to the required cooking temperature.
4. During the 'cook period' the cook symbol [🔥] is illuminated in the display.
5. When cooking is finished an alarm will sound. Press any button to stop the alarm and return to manual cooking. If the alarm is not stopped, it will stop automatically after 7 minutes.

AUTO is Showing, But You Want to Revert to Manual Cooking

You can cancel any automatic settings by pressing the [+] and [-] buttons simultaneously.

Changing the tone of the alarm

It is possible to change the alarm tone.

1. Press the the [+] and [-] buttons simultaneously, then the mode [M] button. The display will show (ton1,2 or 3) (**Fig. 2.30**).
2. To select the tone press the [-] button until desired tone is reached (**Fig. 2.31**).

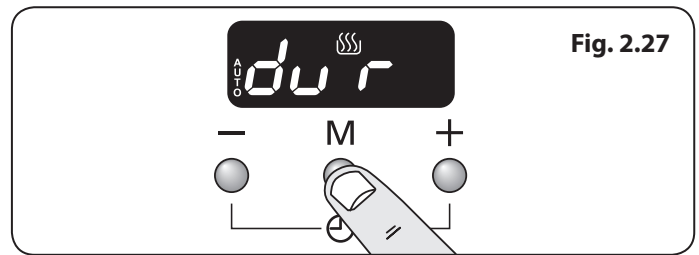

Fig. 2.27

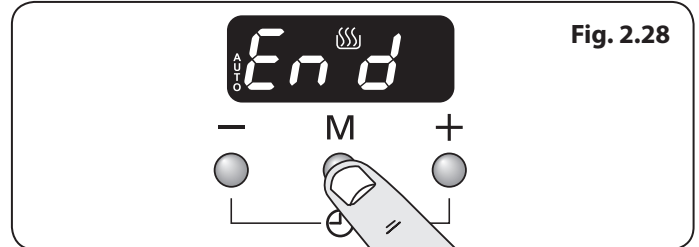

Fig. 2.28

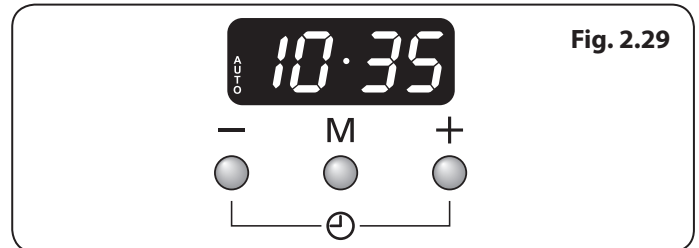

Fig. 2.29

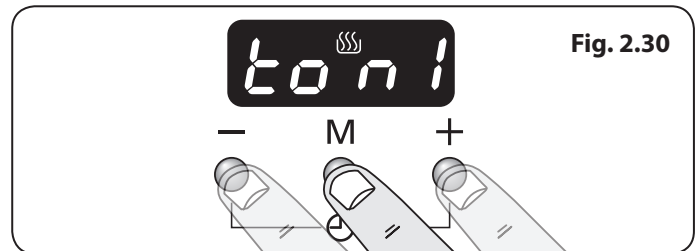

Fig. 2.30

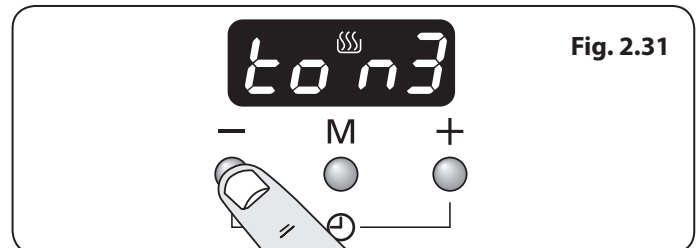

Fig. 2.31

Accessories

Oven Shelves – Left-hand (Main) Oven

The oven shelves (**Fig. 2.32**) are retained when pulled forward but can be easily removed and refitted.

Pull the shelf forward until the back of the shelf is stopped by the shelf stop bumps in the oven sides (**Fig. 2.33**).

Lift up the front of the shelf so the back of the shelf will pass under the shelf stop and then pull the shelf forward (**Fig. 2.34**).

To refit the shelf, line up the shelf with a groove in the oven side and push the shelf back until the ends hit the shelf stop. Lift up the front so the shelf ends clear the shelf stops, and then lower the front so that the shelf is level and push it fully back (**Fig. 2.35**).

Oven Shelves – Right-hand (Tall) Oven

The tall oven is supplied with four flat cooking shelves (**Fig. 2.36**) and a plate warming shelf (**Fig. 2.37**).

When using the tall oven, you can cook on all shelves at the same time, but make sure that they are well spaced out to allow the hot air to circulate.

The Handyrack (Left-hand Oven)

The Handyrack (**Fig. 2.38**) fits to the left-hand oven door only. Food cooking on it is easy to attend to, because it is accessible when the door is open.

The maximum weight that can be held by the Handyrack is 5.5 kg (12 lb). It should only be used with the supplied roasting tin, which is designed to fit the Handyrack. Any other vessel could be unstable.

It can be fitted at two different heights. One of the oven shelves must be removed and the other positioned to suit.

When the Handyrack is used in its highest position, other dishes can be cooked on the bottom shelf position or base of the oven.

When the Handyrack is used in its lowest position, other dishes can be cooked on the second shelf position or base of the oven.

To fit the Handyrack, locate one side of it on the door bracket (**Fig. 2.39**).

Then spring the other side out to clip it onto the other bracket (**Fig. 2.40**).

Oven Light

Press the button to turn the light on (**Fig. 2.41**).

If the oven light fails, turn off the power supply before changing the bulb. See the 'Troubleshooting' section for details on how to change the bulb.

Fig. 2.32

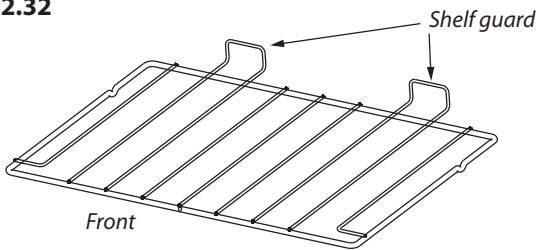

Fig. 2.33

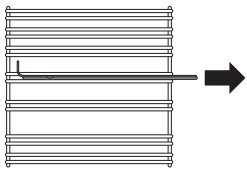

Fig. 2.34

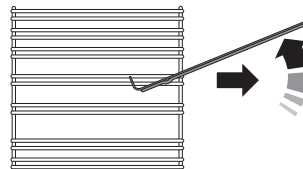

Fig. 2.35

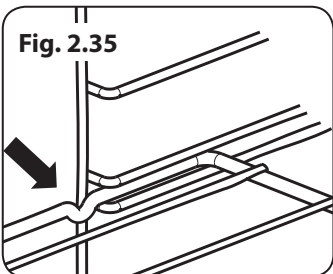

Fig. 2.36

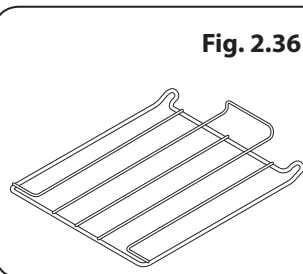

Fig. 2.37

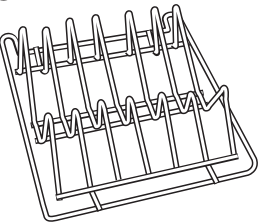

Fig. 2.38

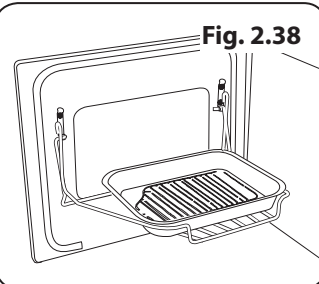

Fig. 2.39

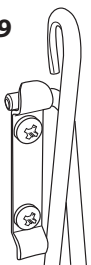

Fig. 2.40

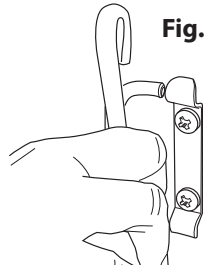

Fig. 2.41





4 Cooking Tips

Tips on Cooking with the Timer

If you want to cook more than one dish, choose dishes that require approximately the same cooking time. However, dishes can be 'slowed down' slightly by using small containers and covering them with aluminium foil, or 'speeded up' slightly by cooking smaller quantities or placing them in larger containers.

Very perishable foods such as pork or fish should be avoided if a long delay period is planned, especially in hot weather.

-  **DO NOT place warm food in the oven to be timed.**
-  **DO NOT use a timed oven that is already warm.**
-  **DO NOT use the timed oven if the adjoining oven is already warm.**

Whole poultry must be thoroughly defrosted before being placed in the oven. Check that meat and poultry are fully cooked before serving.

General Oven Tips

The wire shelves should always be pushed firmly to the back of the oven.

Baking trays with food cooking on them should be placed level with the front edge of the oven's wire shelves. Other containers should be placed centrally. Keep all trays and containers away from the back of the oven, as overbrowning of the food may occur.

For even browning, the maximum recommended size of a baking tray is 340 mm (13½") by 340 mm (13½") in the main oven and 232 mm (9¼") and 321 mm (12⅝") in the tall oven.

When the oven is on, do not leave the door open for longer than necessary, otherwise the knobs may get very hot.

- Always leave a "finger's width" between dishes on the same shelf. This allows the heat to circulate freely around them.
- To reduce fat splashing when you add vegetables to hot fat around a roast, dry them thoroughly or brush lightly with cooking oil.
- Where dishes may boil and spill over during cooking, place them on a baking tray.
- The 'Cook & Clean' oven liners (see '*Cleaning Your Cooker*') work better when fat splashes are avoided. Cover meat when cooking.
- Sufficient heat rises out of the oven while cooking to warm plates in the grill compartment.
- If you want to brown the base of a pastry dish, preheat the baking tray for 15 minutes before placing the dish in the centre of the tray.

5. Cooking Table

The oven control settings and cooking times given in the table below are intended to be used **AS A GUIDE ONLY**. Individual tastes may require the temperature to be altered to provide a preferred result.

Food is cooked at lower temperature in a fan oven than in a conventional oven. When using recipes, reduce the fan oven temperature by 10°C and the cooking time by 5-10 minutes. The temperature in the fan oven does not vary with height in the oven so you can use any shelf.

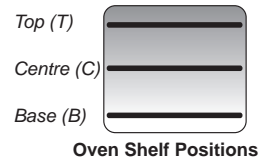

T - Top; C - Centre; B - Base

Food	Conventional Oven	Fan Oven	Approximate Cooking Time	
	Temperature °C (Shelf Position)	Temperature °C		
Meat				
Beef (no bone)	160 (C)	150	30-35 minutes per 500g +30-35 minutes.	<i>Thoroughly thaw frozen joints before cooking. Meat may be roasted at 220°C (210°C for fan oven) and the cooking time adjusted accordingly. For stuffed and rolled meats, add approximately 10 minutes per 500g, or cook at 200°C (190°C) for 20 minutes then 160°C (150°C) for the remainder.</i>
	200 (C)	190	20-25 minutes per 500g +20-25 minutes.	
Lamb	160 (C)	150	30-35 minutes per 500g +30-35 minutes.	
	200 (C)	190	25-30 minutes per 500g +25-30 minutes.	
Pork	160 (C)	150	35-40 minutes per 500g +35-40 minutes.	
	200 (C)	190	25-30 minutes per 500g +25-30 minutes.	
Poultry				
Chicken	160 (C)	150	20-25 minutes per 500g +20-25 minutes.	<i>For stuffed poultry, you could cook at 200°C (190°C) for 20 minutes then 160°C (150°C) for remainder. Do not forget to include the weight of the stuffing.</i>
	200 (C)	190	15-20 minutes per 500g +15-20 minutes.	
Turkey	160 (C)	150	20 minutes per 500g +20 minutes.	
	200 (C)	190	15 minutes per 500g +15 minutes.	
Duck	160 (C)	150	25-30 minutes per 500g.	<i>For fresh or frozen prepacked poultry, follow instructions on the pack. Thoroughly thaw frozen poultry before cooking.</i>
	200 (C)	190	20 minutes per 500g.	
Casserole	140-150 (C)	130-140	2-4 hours according to recipe.	
Yorkshire Pudding	220 (C)	210	Large tins 30-35 minutes; individual 10-20 minutes.	
Cake				
Very rich fruit - Christmas, wedding, etc.	140 (C/B)	130	45-50 minutes per 500g of mixture.	<i>Using the conventional oven: when two tier cooking leave at least one runner space between shelves. Position the baking tray with the front edge along the front of the oven shelf.</i>
Fruit 180 mm tin	150 (C/B)	140	2-2½ hours.	
Fruit 230 mm tin	150 (C/B)	140	Up to 3½ hours.	
Madeira 180 mm	160 (C/B)	150	80-90 minutes.	
Small cakes	170 (C/B)	160	15-25 minutes.	
Scones	200 (C/B)	190	10-15 minutes.	
Victoria sandwich				
180 mm tin	170 (C/B)	160	20-30 minutes.	<i>Up to three tiers can be cooked in a fan oven at the same time but make sure to leave at least one runner space between each shelf being cooked on.</i>
210 mm tin	170 (C/B)	160	30-40 minutes.	
Desserts				
Shortcrust tarts	200 (C/B)	190	20-30 minutes on a preheated tray.	<i>Using the conventional oven: for even browning the maximum size of baking tray recommended is 340 mm x 340 mm. This ensures free heat circulation.</i>
Fruit pies	180 (C/B)	170	35-45 minutes.	
Tartlets	180 (C/B)	170	10-20 minutes according to size.	
Puff pastry	210 (C/B)	200	20-40 minutes according to size.	
Meringues	100 (C/B)	90	2-3 hours.	<i>If cooking a two tier load, the trays should be interchanged approximately halfway through the cooking time.</i>
Baked egg custard	160 (C/B)	150	45-60 minutes.	
Baked sponge pudding	180 (C/B)	170	40-45 minutes.	
Milk pudding	140-150 (C/B)	130-140	2 to 3 hours.	
Bread	210 (C)	200	20-30 minutes.	
Fish				
Fanned Grilling				
Fillet	190 (C/B)	190 (C/B)	15-20 minutes.	
Whole	190 (C/B)	190 (C/B)	15-20 minutes per 500g.	
Steak	190 (C/B)	190 (C/B)	Steaks according to thickness.	

5. Cleaning Your Cooker

Essential Information

Isolate the electricity supply before carrying out any thorough cleaning. Allow the cooker to cool.

⚠ NEVER use paint solvents, washing soda, caustic cleaners, biological powders, bleach, chlorine based bleach cleaners, coarse abrasives or salt.

⚠ DO NOT mix different cleaning products – they may react together with hazardous results.

All parts of the cooker can be cleaned with hot soapy water. **Take care that no surplus water seeps into the appliance.**

Remember to switch on the electricity supply and reset the clock before re-using the cooker.

Hotplate Burners

The burner heads and caps can be removed for cleaning.

⚠ DO NOT put the burner heads in a dishwasher. Make sure they are absolutely dry before replacing them.

The Single Ring Burners

When refitting the burner head, make sure that the notch lines up with the electrode or hole in the base. Check that the burner head is level and that the cap is fitted centrally on the burner head (**Fig. 5.1**).

The Wok Burner

The wok burner can also be taken apart for cleaning.

When reassembling the wok burner (**Fig. 5.2**), turn over the large base ring and find the 'D' shaped area (**Fig. 5.3**). Turn the head until the 'D' matches the one on the burner base. Flip the burner over once again and place it on the burner base.

To fit the small inner burner, find the larger electrode notch in the burner rim. Line this up with the white ignition electrode and place the inner burner on the large base ring (**Fig. 5.4**).

Now fit the two burner caps, making sure that they are seated properly.

Check the burner ports are not blocked. If a blockage occurs, remove stubborn particles using a piece of fuse wire.

The Wok Cradle

Recommended cleaning materials are hot soapy water, a moistened soap pad, cream cleaner or a nylon scourer.

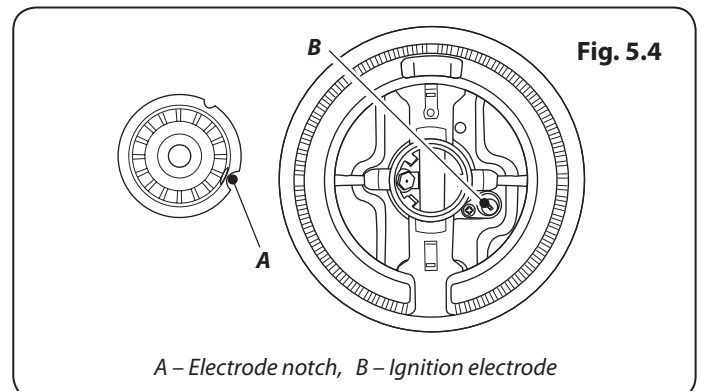
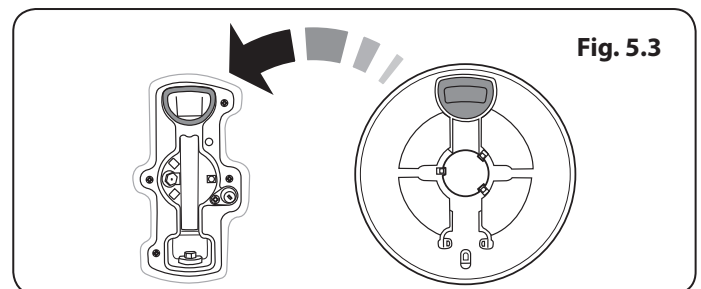
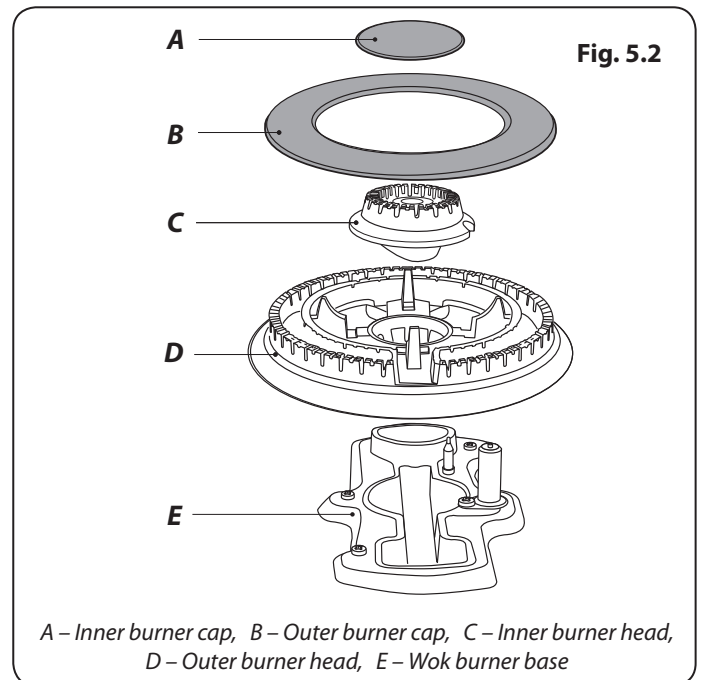
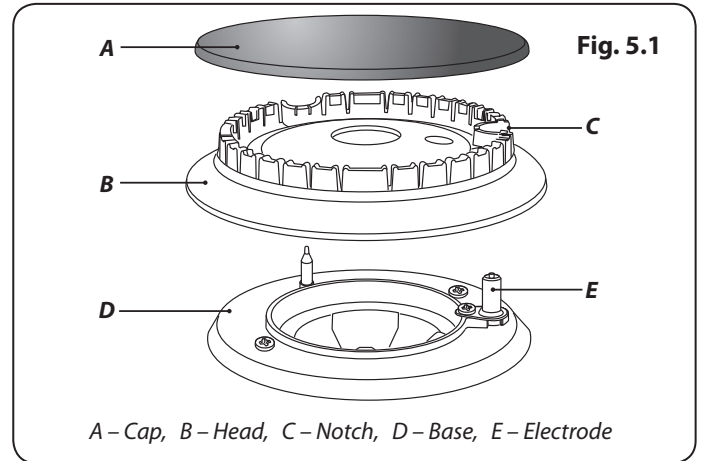
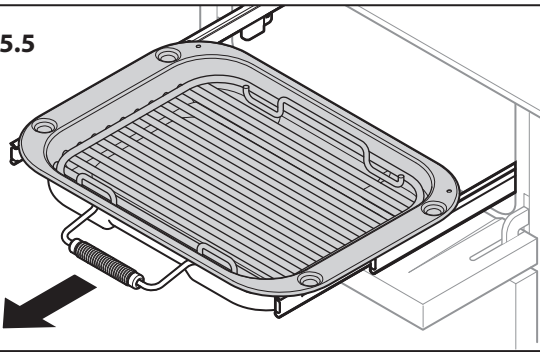

Fig. 5.5



Grills

The grill pan and trivet should be washed in hot soapy water. Alternatively, the grill pan can be washed in a dishwasher.

After grilling meats or any foods that soil, leave to soak for a few minutes immediately after use. Stubborn particles may be removed from the trivet using a nylon brush.

Before you remove any of the grill parts for cleaning, make sure that they are cool, or use oven gloves.

Cleaning the Glide-out Grill

The grill pan can be easily removed for cleaning as follows:

Remove the grill pan support frame by pulling the grill pan forward (**Fig. 5.5**).

Lift the grill pan clear of the support frame. The support frame is held to the side rails by two clips on each side (**Fig. 5.6**).

For each side, support the side rail with one hand and with the other hand lift the frame up and out of the side clips (**Fig. 5.7**).

For safety, push the side rails back into the grill chamber.

If you need to remove the side rails to allow cleaning of the grill chamber, you can unhook them from the grill chamber sides (**Fig. 5.8**) and wipe the sides clean with a soft cloth and mild detergent.

⚠ DO NOT put the side runners in a dishwasher.

Once you have finished, hook the side rails back onto the sides of the chamber. To refit the frame, pull the side rails forward and, for each side in turn, support the side rail and press the frame down into the side rails. Replace the grill pan. When refitting the grill pan, make sure that the wide rim is at the front (**Fig. 5.9**).

Control Panel and Doors

Avoid using any abrasive cleaners, including cream cleaners. For best results, use a liquid detergent.

The same cleaner can also be used on the doors, or alternatively, using a soft cloth wrung out in clean hot soapy water. You can use the same method for cleaning the control panel and knobs.

After cleaning, polish with a dry cloth.

Fig. 5.6

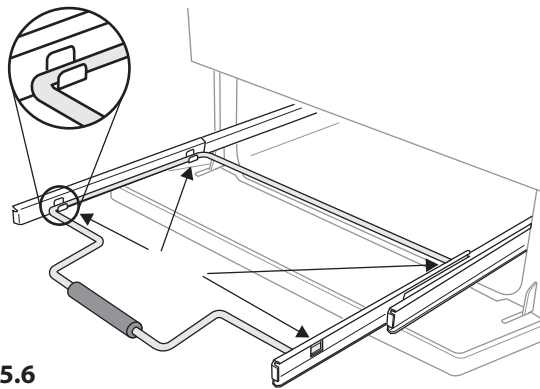

Fig. 5.7

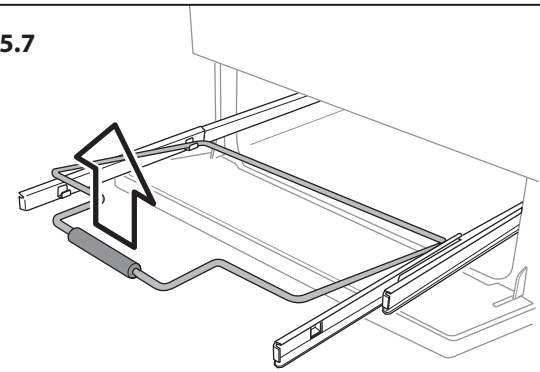

Fig. 5.8

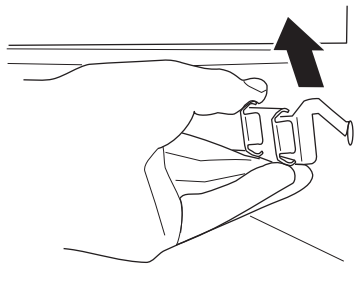
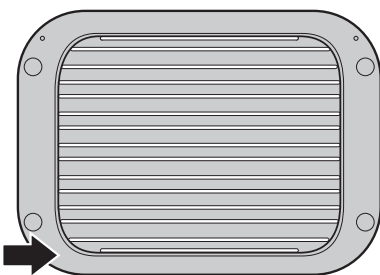

Fig. 5.9



Glass Fronted Door Panels

The oven door front panels can be taken off so that the glass panels can be cleaned. Move the cooker forward to gain access to the sides (see the 'Moving the Cooker' section under 'Installation').

Open the oven door slightly and remove the front panel fixing screws from the door sides, two each side (Fig. 5.10).

Carefully lift off the outer door panel. The inside face of the glass panels can now be cleaned – take care not to disturb or wet the door insulation.

Note: If the door is triple glazed then the inner two panels are fixed together and should not be separated. After cleaning, carefully refit the outer door panel and replace the side fixing screws.

! **DO NOT use harsh abrasive cleaners or sharp metal scrapers to clean the oven door glass since they can scratch the surface, which may result in shattering of the glass.**

Ovens

'Cook & Clean' Panels

The main oven has side 'Cook & Clean' panels which have been coated with a special enamel that partly cleans itself. This does not stop all marks on the lining, but helps to reduce the amount of manual cleaning needed.

These panels work better above 200 °C. If you do most of your cooking below this temperature, occasionally remove the panels and wipe with a lint free cloth and hot soapy water. The panels should then be dried and replaced and the oven heated at 200 °C for about one hour. This will make sure that the panels are working effectively.

Removing the Panels to Clean the Enamel Interior

Some of the lining panels can be removed for cleaning.

If you wish to clean the enamel interior of the oven, you will need to remove the shelves before removing the 'Cook & Clean' panels. You do not have to remove the support brackets to remove the panels. Lift each panel upward and slide forward off the support brackets (Fig. 5.11).

Once the panels have been removed, the oven enamel interior can be cleaned.

DO NOT use steel wool, oven cleaning pads, or any other materials that will scratch the surface.

Refit in the reverse order.

The Tall Oven

To clean the oven sides, slide out the shelves and with both hands gently pull the side supports away (Fig. 5.12).

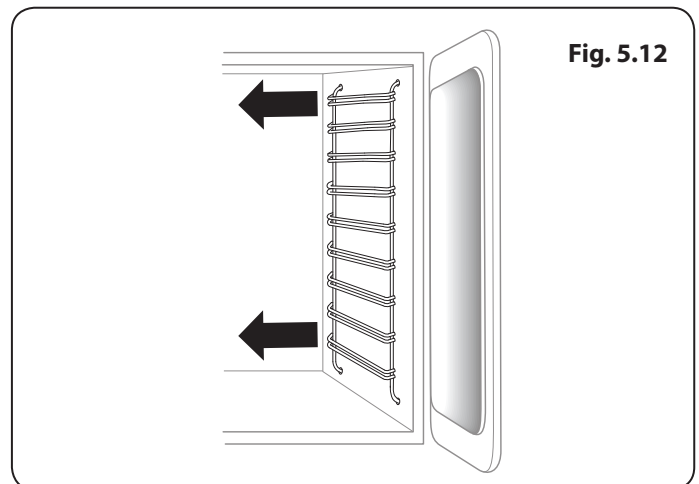
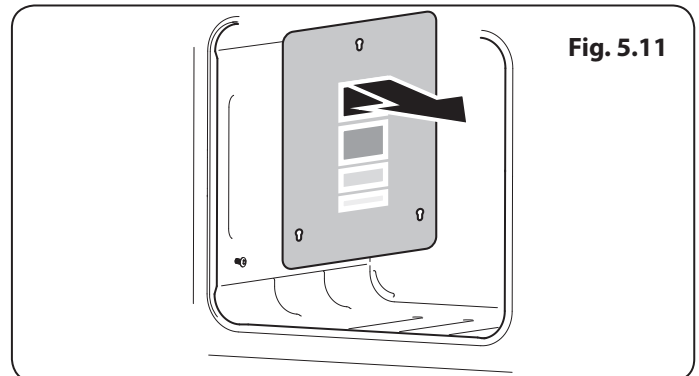
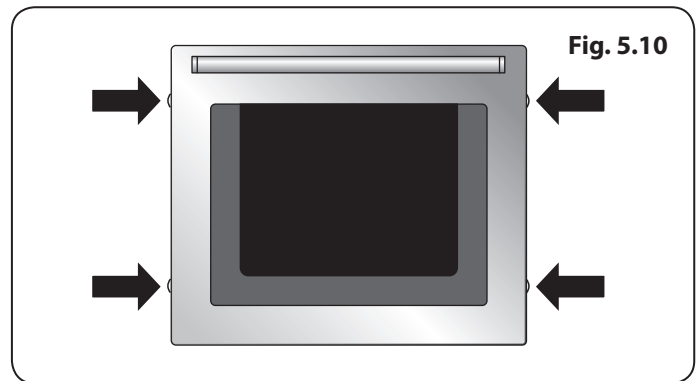

Cleaning Table

Cleaners listed (**Table 5.1**) are available from supermarkets or electrical retailers as stated.

For enamelled surfaces use a cleaner that is approved for use on vitreous enamel.

Regular cleaning is recommended. For easier cleaning, wipe up any spillages immediately.

Hotplate		
Part	Finish	Recommended Cleaning Method
Hob top (including burner heads and caps)	Enamel, stainless steel, aluminium	Hot soapy water, soft cloth. Any stubborn stains remove gently with a nylon scourer.
Ceramic/induction hob	Toughened glass	Hot soapy water; cream cleaner/scourer if necessary.
Griddle plate (some models only)	Non-stick surface	Allow to cool. Wash in hot soapy water. Do not use abrasive cleaners/scourers. Dishwasher.
Warming zone (some models only)	Toughened glass	Hot soapy water, cream cleaner/scourer if necessary.
Outside of Cooker		
Part	Finish	Recommended Cleaning Method
Door, door surround and storage drawer exterior	Enamel or paint	Hot soapy water, soft cloth. Any stubborn stains, remove gently with a liquid detergent.
	Stainless steel	E-cloth (<i>electrical retailers</i>) or microfibre all-purpose cloth (<i>supermarket</i>).
Sides and plinth	Painted surface	Hot soapy water, soft cloth.
Splashback/rear grille	Enamel or stainless steel	Hot soapy water, soft cloth. Cream cleaner, with care, if necessary.
Control panel	Paint, enamel, stainless steel, glass	Warm soapy water. Do not use proprietary cleaners other than washing-up liquid, as this may cause cosmetic damage.
Control knobs/handles & trims	Plastic/chrome, copper or lacquered brass	Warm soapy water, soft cloth.
	Brass	Brass polish.
Oven door glass/glass lid (some models only)	Toughened glass	Hot soapy water, cream cleaner/scourer if necessary.
Oven and Grill		
Part	Finish	Recommended Cleaning Method
Sides, floor & roof of oven NOT 'COOK & CLEAN' OVEN PANELS (see below)	Enamel	Any proprietary oven cleaner that is suitable for enamel. CAUTION: CORROSIVE/CAUSTIC OVEN CLEANERS: FOLLOW MANUFACTURER'S INSTRUCTIONS. Do not allow contact with the oven elements.
'Cook & Clean' oven panels (some models only)	Special enamel that partly cleans itself	This surface cleans itself at 200 °C and above, or the panels can be removed and washed with hot soapy water and a nylon brush.
Oven shelves, Handyrack, grill trivet, Handygrill rack (some models only)	Chrome	An oven interior cleaner that is suitable for chrome. Soap filled pad. Dishwasher.
Grill pan/meat tin (some models only)	Enamel	Hot soapy water. Soap filled pad. Dishwasher.

Table 5.1

6. Troubleshooting

Hotplate/Cooktop ignition or hotplate burners faulty

Is the power on? If not, there maybe something wrong with the power supply.

Are the sparker (ignition electrode) or burner slots blocked by debris?

Are the burner trim and caps correctly located? See the section on *'Cleaning'*.

Hotplate/Cooktop burners will not light

Make sure that the burner parts have been replaced correctly after wiping or removing for cleaning.

Check that there is not a problem with your gas supply. You can do this by making sure that other gas appliances you may have are working.

Do the burners spark when you push the button?

Steam is coming from the oven

When cooking foods with high water content (e.g. oven fries) there may be some steam visible at the rear grille.

Take care when opening the oven door, as there may be a momentary puff of steam when the oven door is opened. Stand well back and allow any steam to disperse.

What cleaning materials are recommended for the cooker?

See the *'Cleaning'* section for recommended cleaning materials.

Never use caustic or abrasive cleaners as these will damage the surface.

An oven fan is noisy

The note of the oven fan may change as the oven heats up – this is perfectly normal.

If there is an installation problem and I don't get my original installer to come back to fix it who pays?

You do. Service organizations will charge for their call outs if they are correcting work carried out by your original installer. It is in your interest to track down your original installer.

Food is cooking too slowly, too quickly, or burning

Cooking times may differ from your previous oven.

Check that you are using the recommended temperatures and shelf positions – see the oven cooking guide. The oven control settings and cooking times are intended to be used **only** as a guide.

Individual tastes may require the temperature to be altered either way, to get the results you want.

The oven is not cooking evenly

Do not use a baking tray with dimensions larger than those specified in the section on *'General Oven Tips'*.

If you are cooking a large item, be prepared to turn it round during cooking.

If two shelves are used, check that space has been left for the heat to circulate. When a baking tray is put into the oven, make sure that it is placed centrally on the shelf.

Check that the door seal is not damaged and that the door catch is adjusted so that the door is held firmly against the seal.

A dish of water when placed on the shelf should be the same depth all over. (For example, if it is deeper at the back, then the back of the cooker should be raised up or the front lowered.) If the cooker is not level, arrange for your supplier to level it for you.

Oven not coming on

Is the power on? If not, there may be something wrong with the power supply.

Is the cooker supply on at the isolator switch?

Oven temperature getting hotter as the cooker gets older

If turning the temperature down using the oven control knob has not worked, or has only worked for a short time, then you may need a new thermostat. This should be fitted by a qualified service person.

Fig. 6.1

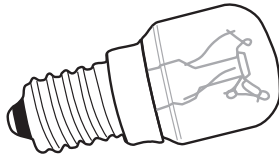

Oven light is not working

The bulb has probably burnt out. You can buy a replacement bulb (which is not covered under the warranty) from a good electrical shop. Ask for a 15W – 230V lamp, FOR OVENS. It must be a special bulb, heat resistant to 300°C (**Fig. 6.1**).

Turn off the power at the circuit breaker.

Before removing the existing bulb, turn off the power supply and make sure that the oven is cool. Open the oven door and remove the oven shelves.

Unscrew the bulb cover by turning counter-clockwise. It may be very stiff (**Fig. 6.2**).

Taking care to protect your fingers with a glove in case the bulb should shatter, unscrew the old bulb.

Screw in the new bulb; screw back the bulb cover. Turn on the circuit breaker and check that the bulb now lights.

Fig. 6.2

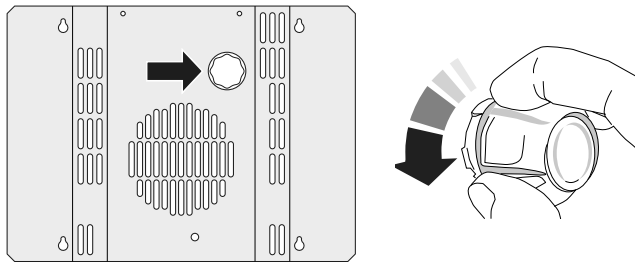

The left-hand oven door is misaligned

The bottom hinge of the left-hand oven door can be adjusted to alter its angle (**Fig. 6.3**).

Loosen the bottom hinge fixing screws and use the notch and a flat bladed screwdriver to move the position of the hinge to set the hinge position (**Fig. 6.4**).

Retighten the hinge screws.

Note: The tall oven door cannot be adjusted

Fig. 6.3

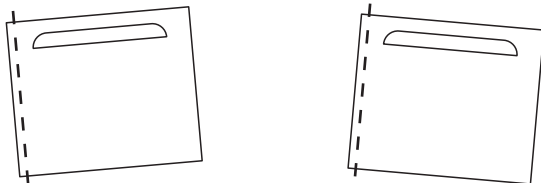

Effect of hinge adjustment – exaggerated for clarity

Grill

The fascia gets hot when I use the oven or grill

The cooker is cooled by a fan. If the fascia becomes excessively hot when the cooker is in use then the cooling fan may have failed. Should this occur please contact your installer, a qualified repair engineer or Customer Service to arrange for its repair.

The knobs get hot when I use the oven or the grill. Can I avoid this?

Yes, this is caused by heat rising from the oven or the grill, and heating them up. Do not leave the oven door open.

Make sure that the grill pan is pushed right back to the 'back stop' when grilling.

Always grill with the grill compartment door open.

Fig. 6.4

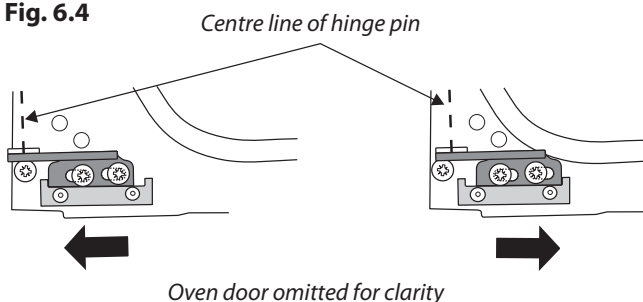

INSTALLATION

Check the appliance is electrically safe and gas sound when you have finished.

7. Installation

Service and Spares

Firstly, please complete the appliance details below and keep them safe for future reference – this information will enable us to accurately identify the particular appliance and help us to help you. Filling this in now will save time and inconvenience if you later have a problem with the appliance. It may also be of benefit to keep your purchase receipt with this leaflet. You may be required to produce the receipt to validate a warranty field visit.

Distributor's Name and Address	Andi-Co Australia Pty Ltd. 1 Stamford Road, Oakleigh, VIC 3166 Customer Care Tel: 1300 650 020 Email: service@andico.com.au
Name of Appliance	Nexus 90 Dual Fuel
Appliance Serial Number*	
Fuel Type	Dual Fuel
Date of Purchase	
Installer's Name, Address and Telephone No.	
Date of Installation	

*This information is on the appliance data badge.

If You Have a Problem

In the unlikely event that you have a problem with your appliance, please refer to rest of this booklet, especially the problem solving section, first to check that you are using the appliance correctly.

If you are still having difficulty, contact Customer Care on 1300 650 020 or email service@andico.com.au.

Please Note

For warranty information and how to request a remedy, please refer to the warranty document provided with the appliance or contact Customer Care.

Out of Warranty

We recommend that our appliances are serviced regularly throughout their life to maintain the best performance and efficiency. The frequency of service will depend on usage – for normal usage once a year should suffice.

Service work should only be carried out by a suitably Authorised Person.

Spare Parts

To maintain optimum and safe performance, we recommend that only genuine spare parts are used. Do not use re-conditioned or unauthorised controls. Contact Spare Parts on (03) 9569 7744 or email spares@andico.com.au

INSTALLATION

Check the appliance is electrically safe and gas sound when you have finished.

Safety Requirements and Regulations

You must be aware of the following safety requirements & regulations.

- ⚠ Before installation, make sure that the local distribution conditions (nature of the gas and gas pressure) and the adjustment of the appliance are compatible.**
- ⚠ The appliance must be installed in accordance with the regulations in force and only in a well ventilated space.**
- ⚠ Read the instructions before installing or using this appliance.**

The regulations and standards are as follows:

- **AS/NZS 5601 – ‘Gas Installations’**
- **AS/NZS 3000 - ‘Wiring Rules’**

In your own interest and that of safety, it is law that all gas appliances be installed by competent persons.

- ⚠ Failure to install the appliance correctly could invalidate any warranty or liability claims and lead to prosecution.**

The cooker must be installed in accordance with all local gas fitting regulations, municipal building codes, electrical wiring regulations and any other relevant statutory regulations.

- ⚠ WARNING!**
Where this appliance is installed in marine craft, in caravans or in mobile homes it shall NOT be used as a space heater.

Provision of Ventilation

This appliance is not connected to a combustion products evacuation device. Particular attention shall be given to the relevant requirements regarding ventilation.

All rooms require a window that can be opened, or equivalent, while some rooms require a permanent vent in addition to the window.

Location of Cooker

The cooker may be installed in a kitchen/kitchen diner but NOT in a room containing a bath or shower.

Where the appliance is installed next to cabinetry, the cabinet material must be capable of withstanding 70°C. If this appliance is installed near vinyl wrapped surfaces, use an installation kit available from the vinyl-wrap supplier. Falcon cannot accept any responsibility for damage caused due to installation into cabinets with low temperature tolerances.

This appliance is designed for domestic cooking only. Use for any other purpose could invalidate any warranty or liability claim.

Note: An appliance for use on LPG must not be installed in a room or internal space below ground level, e.g. in a basement.



Conversion

All models are supplied set for use on Natural gas. A conversion kit for Propane gas is included with the appliance. See the instructions that are supplied with the conversion kit.

After converting the appliance, please attach the Gas Conversion sticker over the appropriate area of the data badge - this will identify the gas type for which the appliance is now set.

INSTALLATION

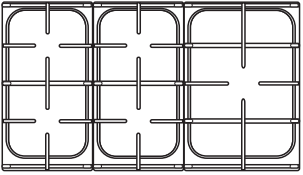
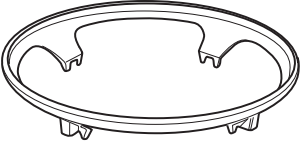
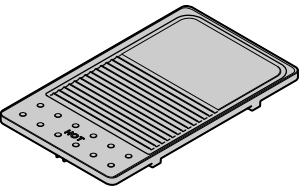
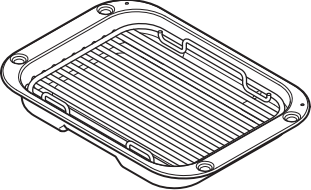
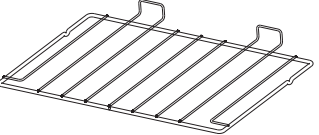
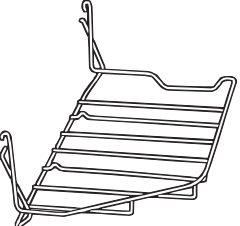
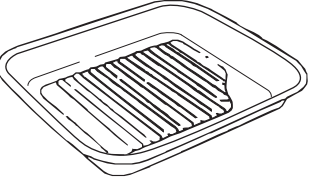
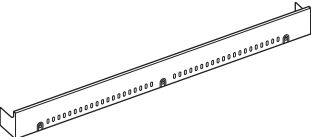
Check the appliance is electrically safe and gas sound when you have finished.

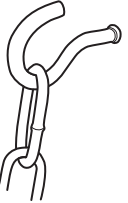
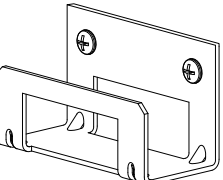
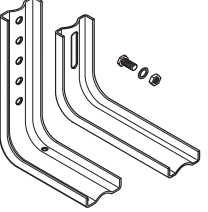
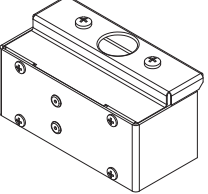
<i>3 pan supports</i>	<i>Wok cradle</i>
	
<i>Griddle plate</i>	<i>Grill pan & trivet</i>
	
<i>2 flat shelves</i>	<i>Handyrack</i>
	
<i>Roasting tin</i>	<i>Plinth</i>
	
<i>Tall oven shelves and shelf supports (example shown)</i>	<i>Restraining chain & hook *</i>
	
<i>Stability location bracket</i>	<i>Stability bracket</i>
	
<i>Conduit box</i>	
	

You will need the following equipment to complete the cooker installation satisfactorily:

- *** Restraining chain and hook:**
If the cooker is to be supplied with gas through a flexible hose, a restraining chain and hook **MUST** be fitted. **These are not supplied with the cooker** but are available at most builders' merchants.
- Flexible gas hose: Must be in accordance with the
- relevant standards.
- Gas pressure tester/manometer.
- Multimeter: For electrical checks.

You will also need the following tools:

1. Electric drill
2. Masonry drill bit (only required if fitting the cooker on a stone or concrete floor)
3. Wall plugs (only required if fitting the cooker on a stone or concrete floor)
4. Steel tape measure
5. Cross head screwdriver
6. Flat head screwdriver
7. Spirit level
8. Pencil
9. Adjustable spanner
10. 13 mm spanner or socket wrench
11. Screws for fitting the restraining chain and bracket

INSTALLATION

Check the appliance is electrically safe when you have finished.

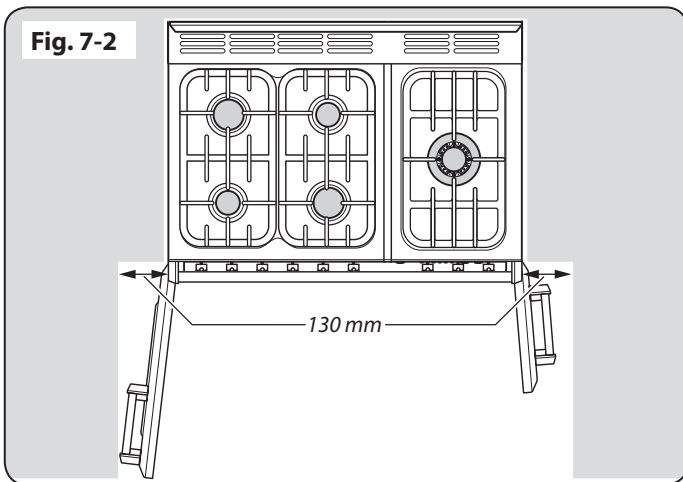
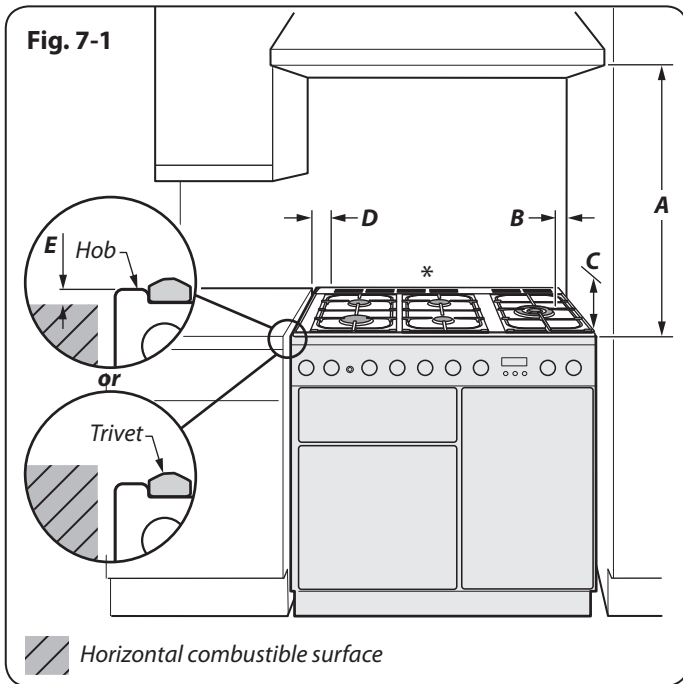

Positioning the Cooker

The diagram (**Fig. 8.1**) shows the minimum recommended distance from the cooker to nearby surfaces as given in AS/NZS 5601.

*Any splashback must be fitted in accordance with the manufacturer's instructions. Allowance should be made for the additional height of the flue trim, which is fitted to the cooker hob.

1. Overhead - Measurement A

The minimum height of any surface above the cooker is 650 mm above the hotplate.

Cookerhoods and exhaust fans shall be installed in accordance with the manufacturer's instructions. However, in no case shall the clearance between the highest part of the hob of the cooking appliance and a cookerhood be less than 650 mm or, for an overhead exhaust fan, 750 mm.

2. Side Clearances - Measurements B & C

Where **B**, measured from the periphery of the nearest burner to any vertical combustible surface is less than 200 mm, the surface shall be protected by one of the following methods:

- Fixing ceramic tiles with a minimum thickness of 5 mm to the surface.
- Fixing toughened glass with a minimum thickness of 5 mm to the surface, provided the glass is approved by the manufacturer to be suitable for the application.
- Attaching fire resistant material to the surface and covering with sheet metal with a minimum thickness of 0.4 mm.

Protection should be to a height **C** of not less than 150 mm above the hob for the full dimension (width or depth) of the cooking surface area.

3. Side Clearances - Measurement D & E

Where **D**, the distance from the periphery of the nearest burner to a horizontal combustible surface is less than 200 mm, then **E** shall be 10 mm or more, or the horizontal surface shall be above the trivet.

If the horizontal surface is above the trivet, then any vertical combustible surface needs to be protected in accordance with **B** above.

If the cooker is near a corner of the kitchen, a clearance of 130 mm is required to allow the oven doors to open (**Fig. 8.2**). The actual opening of the doors is slightly less, but this allows for some protection of your hand as you open the door.

DO NOT place the cooker on a base.

For safety reasons, curtains must not be fitted immediately behind the cooker.

We recommend a gap of 910 mm between units to allow for moving of the cooker. Do not box the cooker in – it must still be possible to move the cooker in and out for cleaning and servicing.

INSTALLATION

Check the appliance is electrically safe and gas sound when you have finished.

Moving the Cooker

⚠ On no account try and move the cooker while it is plugged into the electricity supply.

⚠ The cooker is very heavy, so take extra care.

We recommend that two people manoeuvre the cooker. Make sure that the floor covering is firmly fixed, or removed, to prevent it being disturbed when moving the cooker around.

To help you, there are two levelling rollers at the back, and two screw-down levelling feet at the front.

Remove the polystyrene base pack. From the front, tilt the cooker backwards and remove the front half of the polystyrene base (**Fig. 7.1**).

Repeat from the back and remove the rear half of the polystyrene base.

Lowering the Two Rear Rollers

To adjust the height of the rear of the cooker, first fit a 13 mm spanner or socket wrench onto the hexagonal adjusting nut (**Fig. 7.2**). Rotate the nut – clockwise to raise – counter-clockwise to lower.

Make 10 complete (360°) turns clockwise.

Make sure you lower BOTH REAR ROLLERS.

Completing the Move

Unfold the rear edge of the cardboard base tray. Open the oven door(s) so that you can get a good grip on the bottom of the fascia panel as you move the oven (**Fig. 7.3**).

Carefully push the cooker backwards off the base tray. Remove the base tray.

Position the cooker close to its final position, leaving just enough space to get behind it (**Fig. 7.4**).

⚠ DO NOT use the door handles or control knobs to manoeuvre the cooker.

Levelling

You are recommended to use a spirit level on a shelf in one of the ovens to check for level.

Place the cooker in its intended position, taking care not to twist it within the gap between the kitchen units as damage may occur to the cooker or the units.

The front feet and rear rollers can be adjusted to level the cooker. To adjust the height of the rear of the cooker turn the adjusting nuts at the front bottom corners of the cooker. To set the front feet turn the bases to raise or lower.

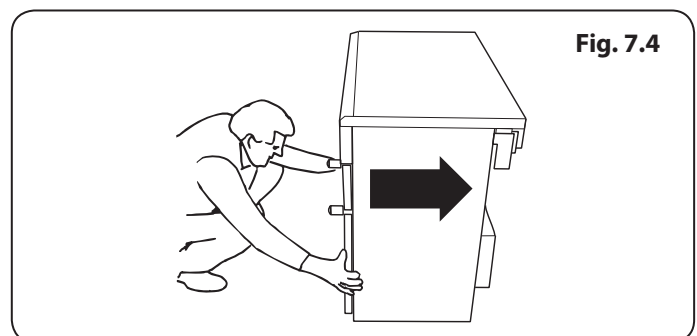
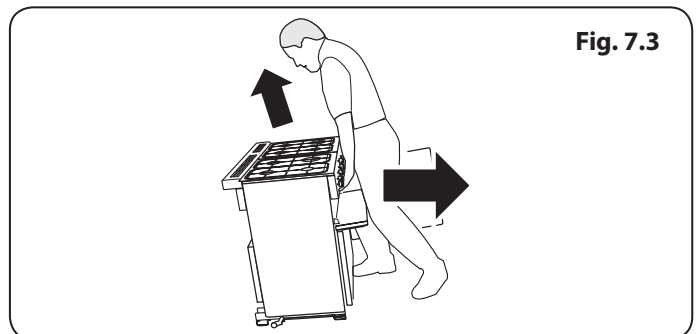
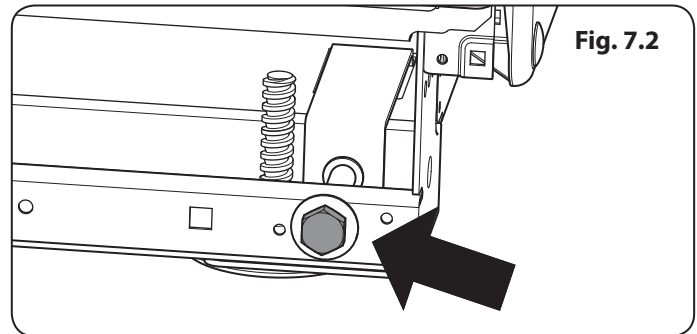
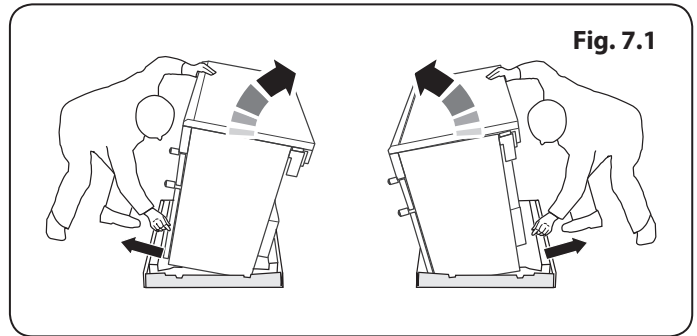

INSTALLATION

Check the appliance is electrically safe and gas sound when you have finished.

Fig. 7.5

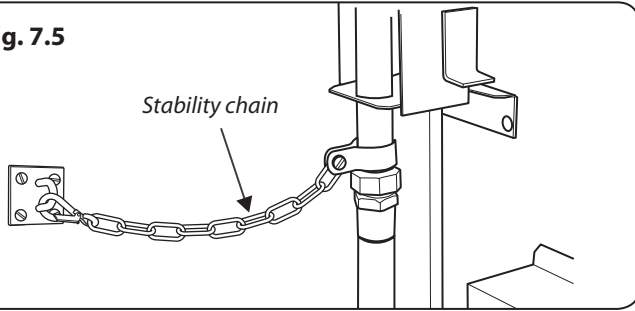

Fitting the Stability Bracket or Chain

Unless otherwise stated, a cooker using a flexible gas connector must be secured with a suitable stability device.

Suitable stability devices are shown in **Fig. 7.5**, **Fig. 7.6**, **Fig. 7.7** and **Fig. 7.8**.

If you are using a stability chain (**Fig. 7.5**) then the chain should be kept as short as is practicable and fixed firmly to the rear of the cooker.

If you are using a stability bracket; first attach the bracket location device to the rear of the cooker (**Fig. 7.6**). Then adjust the bracket to engage through the slot of the device (**Fig. 7.7** and **Fig. 7.8**).

Fig. 7.6

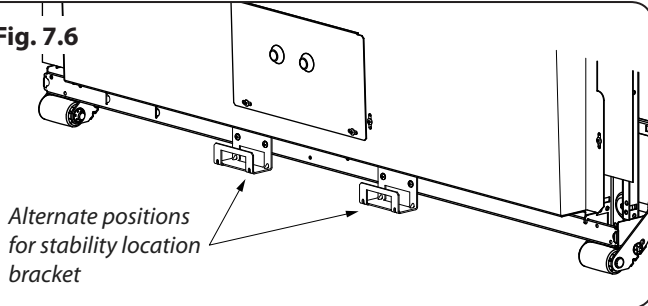

Repositioning the Cooker Following Connection

If you need to move the cooker once it has been connected then you need to unplug it and, having gripped under the fascia panel and lifted the front of the cooker slightly (**Fig. 7.3**), you need to check behind the cooker to make sure that the gas hose is not caught.

As you progress, make sure that both the electricity cable and gas hose always have sufficient slack to allow the cooker to move.

With a stability chain fitted, release it as you ease the cooker out. Do not forget to refit it when you replace the cooker.

When you replace the cooker, again check behind to make sure that the electricity cable and gas hose are not caught or trapped.

Fig. 7.7 Stability bracket

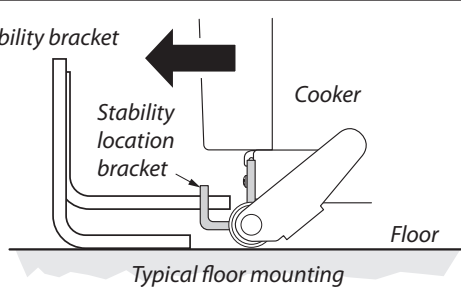
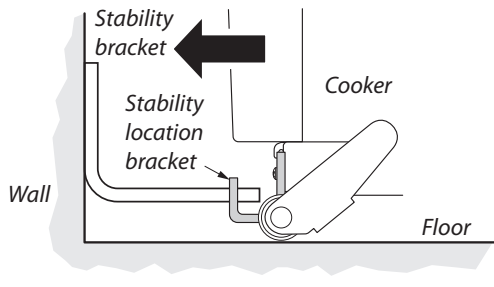

Fig. 7.8



INSTALLATION

Check the appliance is electrically safe and gas sound when you have finished.

Gas Connection

This must be in accordance with the relevant standards.

The gas supply needs to terminate with a down-facing threaded fitting $\frac{1}{2}$ " connection. The inlet connector is located just below the hotplate level at the rear of the cooker.

Because the height of the cooker can be adjusted and each connection is different, it is difficult to give precise dimensions. Ideally the hose supply connection should be within the shaded area 'A' (Fig. 7.1).

Means of isolation must be provided at the supply point by either an approved quick-connect device or a Type 1 manual shut-off valve.

The hose should be fitted so that both inlet and outlet connections are vertical so that the hose hangs downwards in a 'U' shape.

A flexible connection is supplied with the cooker. If it is necessary to use another hose it must be to AS 1869 class B and be suitable for your gas type.

If in doubt contact your supplier. Screw connect the threaded end of the hose into the gas inlet.

After completing the gas connection, check the cooker is gas sound with a pressure test. When checking for gas leaks do not use washing up liquid – this can corrode. Use a product specifically manufactured for leak detection.

Natural Gas

The gas pressure regulator is preset to give a nominal pressure of 1 kPa on Natural Gas. Connect to the Rp $\frac{1}{2}$ inlet on the underside of the pressure regulator.

Propane

This cooker is supplied ready for use on natural gas. A conversion kit for Propane as is supplied with the cooker – see the 'Conversion to Propane Gas' section.

Pressure Testing

The pressure test point is accessible on the inlet pipe at the rear. Remove the test nipple screw and fit a pressure gauge to the test point. Turn on and light two of the hotplate burners.

For Natural Gas cookers the operating pressure should be 1 kPa.

For Propane X cookers the operating pressure should be 2.54 kPa.

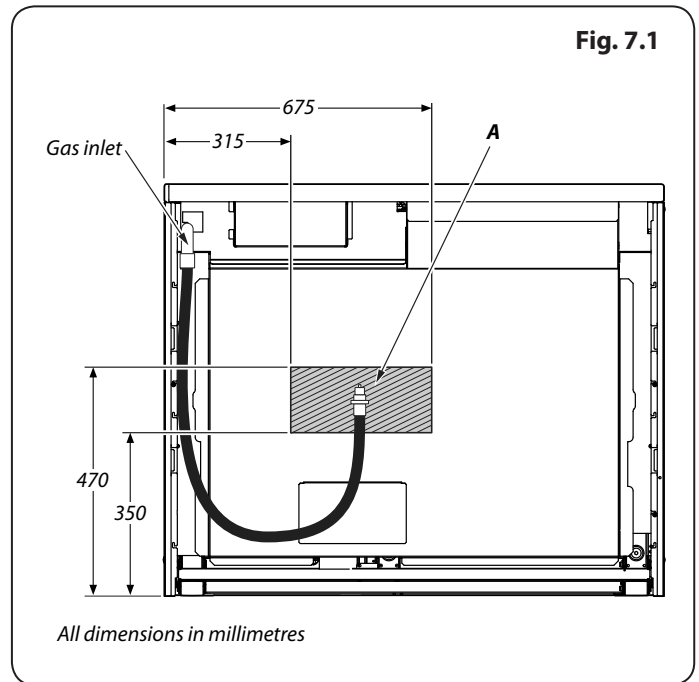

INSTALLATION

Check the appliance is electrically safe and gas sound when you have finished.

Fig. 7.1

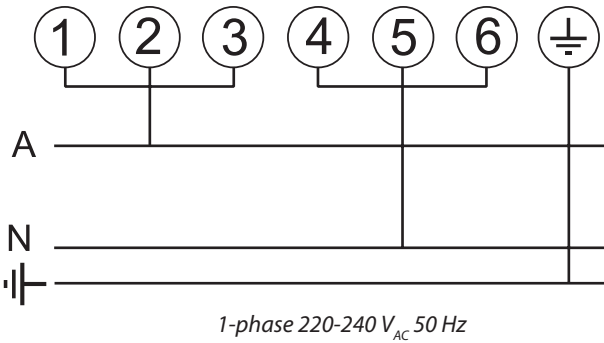
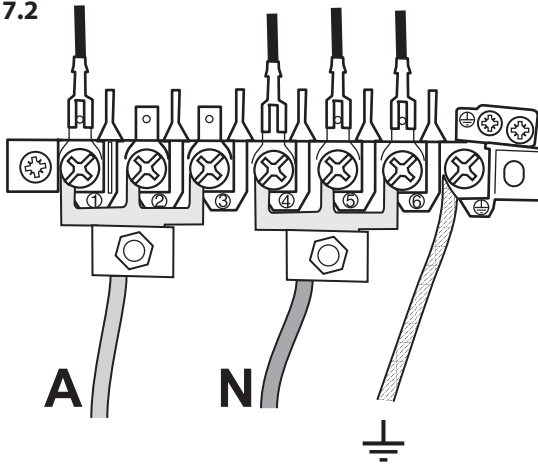

Fig. 7.2



Electrical Connection

This appliance must be installed by a qualified electrician to comply with with current AS/NZS 3000 Wiring Rules and regulations in force.

Make sure that the mains characteristics (voltage, nominal, power, etc.) match the ratings indicated on the data plate affixed to the cooker.

The cooker is preset for a single-phase earthed electrical connection. It is essential to install a multi-pole circuit breaker that completely disconnects the appliance from the mains, with a minimum contact break distance of 3 mm.

Current Operated Earth Leakage Breakers

The combined use of your cooker and other domestic appliances may cause nuisance tripping, so we recommend that the cooker is protected on an individual RCD (Residual Current Device) or RCBO (Residual Current Breaker with Overload).

IF IN DOUBT, PLEASE CONSULT A SUITABLY QUALIFIED ELECTRICIAN.

⚠ WARNING: THIS APPLIANCE MUST BE EARTHED.

The appliance must be connected to an efficient earthing circuit. If the electricity network is not equipped with an earth connection, then it must be installed separately in compliance with local regulations.

Earthing is a safety measure required by law, and must be performed with particular care by a qualified technician, who must also check that the electricity supply characteristics are correct.

The total electrical load of the appliance is approximately 10 kW. The cable size used should be suitable for this load and comply with all local requirements (i.e. PVC Insulated cable IEC 60227 – code 53 for ordinary cables).

Access to the mains terminal is gained by removing the electrical terminal cover box on the back panel. Connect the mains cable to the correct terminals for your electrical supply type (**Fig. 7.1** and **Fig. 7.2**). Check that the links are correctly fitted and that the terminal screws are tight. Secure the mains cable using the cable clamp.

An isolation switch shall be provided and mounted near the cooker, in a readily accessible position, in compliance with AS/NZS 3000 and/or AS/NZS 5601 as applicable for the appliance configuration.

INSTALLATION

Check the appliance is electrically safe and gas sound when you have finished.

Fixed Wiring

⚠ Disconnect from the mains supply.

For connection to fixed wiring, i.e. flexible conduit, Remove the electrical terminal cover on the back panel (**Fig. 7.3**).

Remove the M4 screw securing the reducer plates to the conduit box (**Fig. 7.4**). Fit the conduit box to the cooker using the two M5 screw fittings located at the top of the box and the M4 screw (**Fig. 7.5**).

The conduit box cover is reversible. Fit the reducer plates, if required (**Fig. 7.6**). Feed the cable through the conduit box and secure in place with the cable clamp.

Connect the mains cable to the correct terminals for your electrical supply type (**Fig. 7.7**). Check that the links are correctly fitted and that the terminal screws are tight.

Fit the cover to the conduit box.

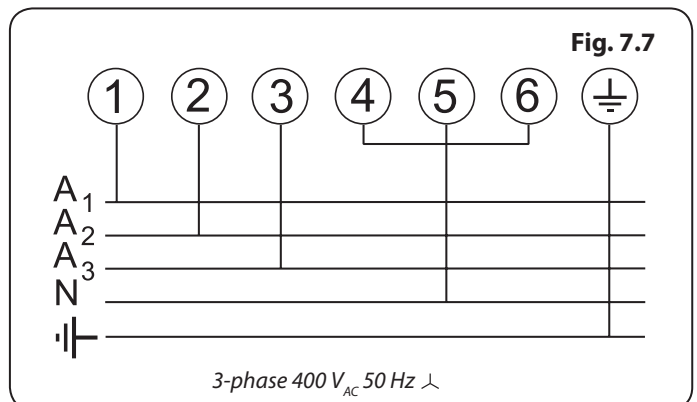
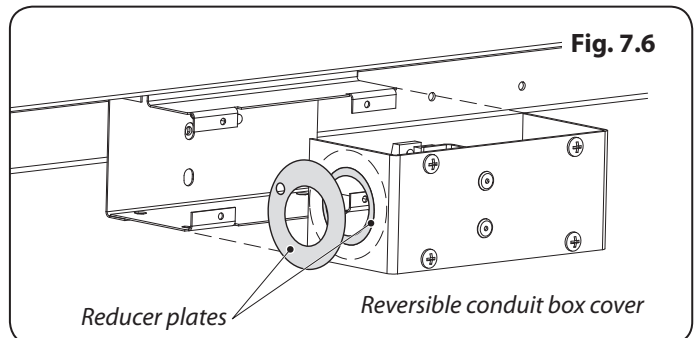
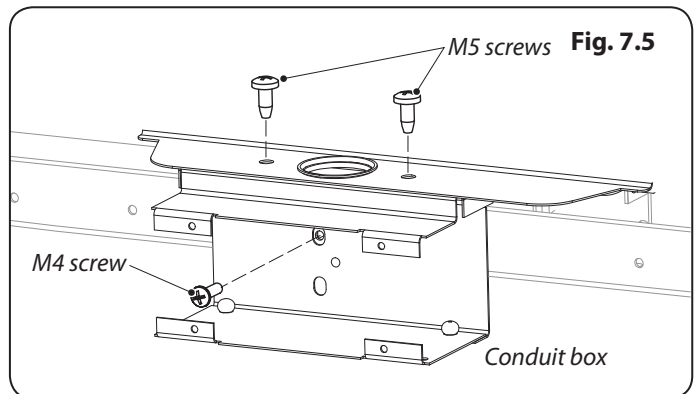
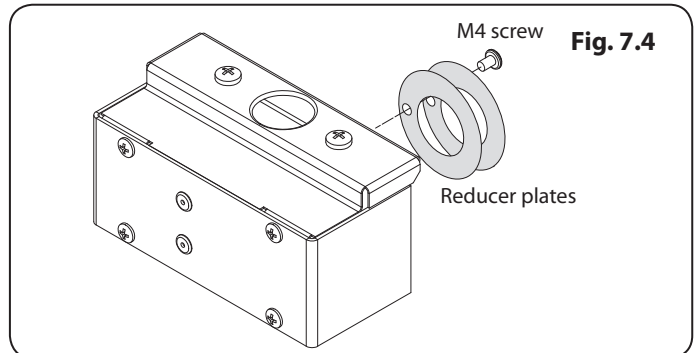
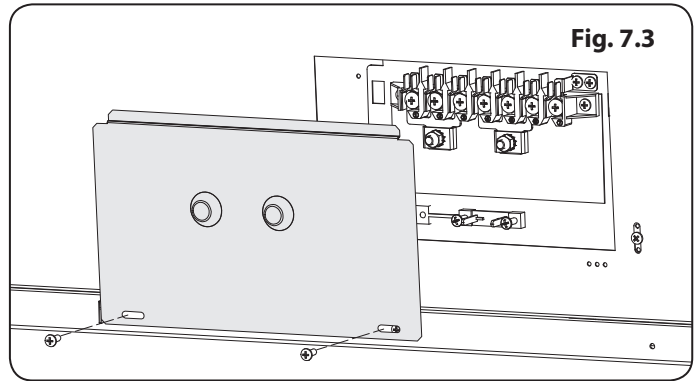

INSTALLATION

Check the appliance is electrically safe when you have finished.

8. Final Fitting

Final Checks

Hob Check

Check each cooking zone in turn. Be sure to use pans of the correct size and material.

Grill Check

Turn on the grill control and check that the grill heats up.

Oven Check

Set the clock as described earlier, and then turn on the ovens. Check the oven fans start to turn and that the ovens heat up.

Final Fitting

Fitting the Plinth

Remove the 3 screws along the front bottom edge of the cooker. Position the plinth, replace and tighten 2 of the fixing screws (**Fig. 8-1**). The third can be discarded.

Customer Care

Installer: Please complete your details in this guide, inform the user how to operate the cooker and hand over the instructions.

Thank you.

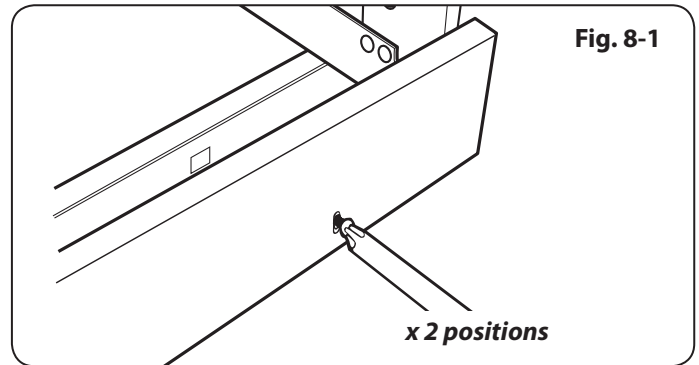

WARNING – SERVICING TO BE CARRIED OUT ONLY BY AN AUTHORISED PERSON
Disconnect from electricity and gas before servicing. Check appliance is safe when you have finished.

9. Conversion to LP Gas

Conversion from Natural Gas (1.0 kPa) to LPG X Propane (2.54 kPa)

- ⚠** A suitably competent person must perform the conversion. After conversion the installation must comply with the relevant regulations and also the local electricity supply company requirements. Read the instructions before converting this appliance.
- ⚠** Failure to convert the appliance correctly could invalidate any warranty or liability claims and lead to prosecution.
- ⚠** When servicing or replacing gas-carrying components disconnect from the gas supply before starting operation. Check the appliance is gas sound after completion.
- ⚠** DO NOT use reconditioned or unauthorised gas controls.
- ⚠** Disconnect from the electricity and gas supply before servicing.
- ⚠** Before electrical reconnection, check that the appliance is electrically safe.

Injectors

Remove the burner caps and heads. Remove the old jets (**Fig. 9.1**). Fit the new jets (see the 'Technical Data' section at the back of this book for the correct jets). Reassemble in reverse order.

Tap Adjustment

Removing the Control Panel

Remove the handrail. Now remove the 2 cross-headed screws hidden behind the handrail end brackets (**Fig. 9.2**).

Pull off all the control knobs and remove the fixing screws underneath the control panel.

Lift the control panel and pull forwards, taking care not to damage or strain the wiring.

Bypass Screw Adjustment

Turn the bypass screw on each control clockwise to the stop (**Fig. 9.3**). Refit the control panel.

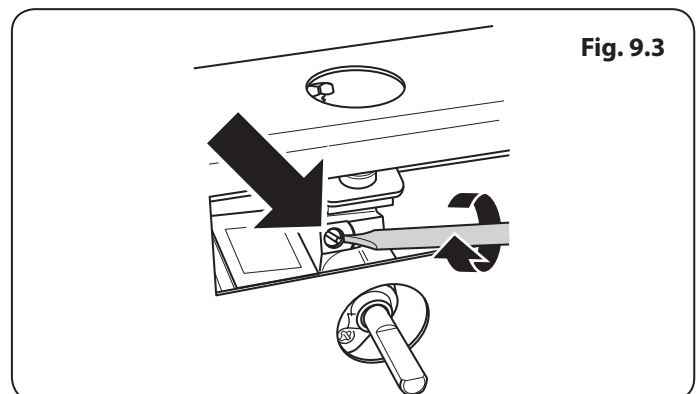
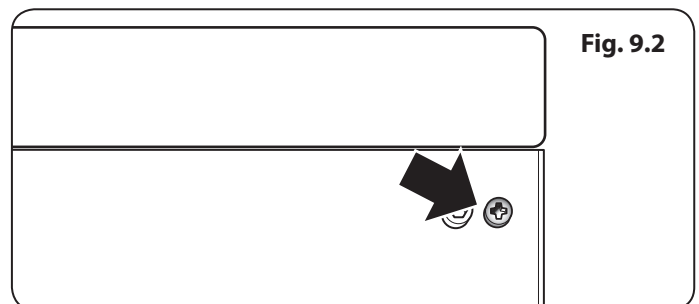
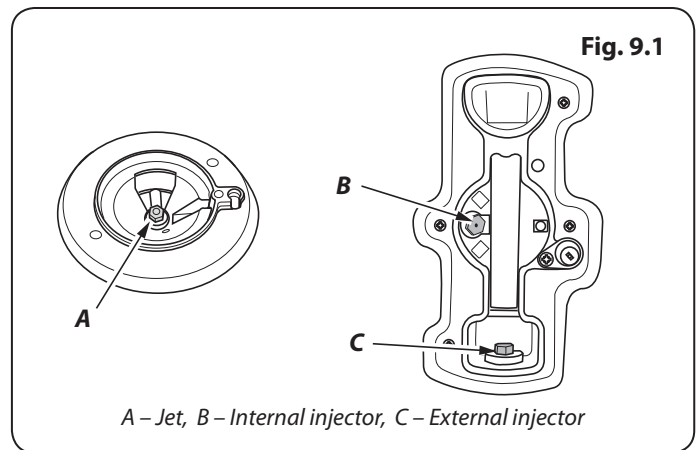

WARNING – SERVICING TO BE CARRIED OUT ONLY BY AN AUTHORISED PERSON
Disconnect from electricity and gas before servicing. Check appliance is safe when you have finished.

Fig. 9.4

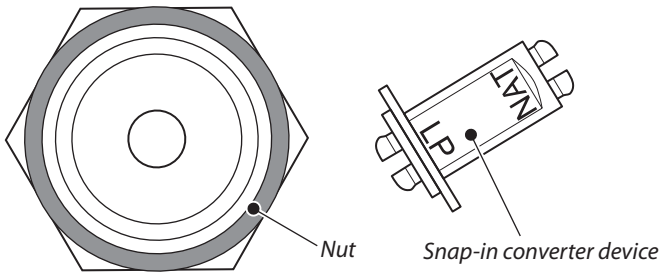

Set the Governor

Unscrew the governor's brass top. In the base of the brass top is a plastic snap-in converter device (**Fig. 9.4**). To convert the governor, snap the device out of the top and refit it the other way round. The snap-in converter device is marked to show the gas for which it is set (**Fig. 9.5**).

Make sure the device is secure in the top cap and refit the cap to the governor.

Pressure Testing

The pressure test point is accessible on the inlet pipe at the rear. Remove the test nipple screw and fit a pressure gauge to the test point. Turn on and light two of the hotplate burners.

For Propane X cookers the operating pressure should be 2.54 kPa.

- ▲ Check the appliance is gas sound.**
- ▲ Check operation of all the burners.**

Fig. 9.5

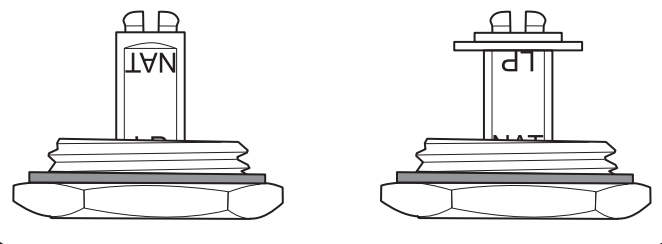

Affix Label

Stick the appropriate gas label over the natural gas part of the appliance data label.

WARNING – SERVICING TO BE CARRIED OUT ONLY BY AN AUTHORISED PERSON
Disconnect from electricity before servicing. Check appliance is safe when you have finished.

10. Servicing

- ⚠ BEFORE SERVICING ANY GAS CARRYING COMPONENTS TURN OFF THE GAS SUPPLY**
- ⚠ Check the appliance is gas sound after completion of service. When checking for gas leaks DO NOT use washing up liquid – this can corrode. Use a product specifically manufactured for leak detection.**
- ⚠ DO NOT use reconditioned or unauthorised gas controls.**
- ⚠ Disconnect from the electricity supply before servicing, particularly before removing any of the following: control panel, side panels, hotplate tray or any electrical components or covers.**
- ⚠ Before electrical reconnection, check that the appliance is electrically safe.**

1 Panels

1.1 To Remove the Control Panel

DISCONNECT FROM THE ELECTRICITY SUPPLY.

Removing the Control Panel

Pull off all the control knobs and remove the fixing screws underneath the control panel.

The control panel will drop down slightly. It is held at the top by two holes in the top edge, one at each end, that locate on the tags on the inner panel. Lift the control panel clear of the tags and pull forwards, taking care not to damage or strain the wiring.

1.2 To Remove the Side Panels

DISCONNECT FROM THE ELECTRICITY SUPPLY.

Remove the control panel (see 1.1). Pull the cooker forward. Remove the 4 retaining screws for each panel (1 at the front base, 1 on the top and 2 at the rear).

Reassemble in reverse order.

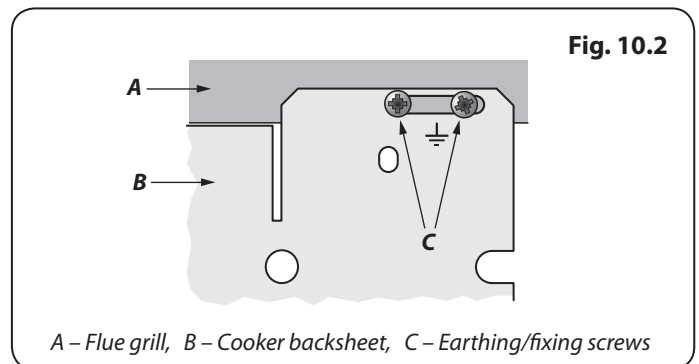
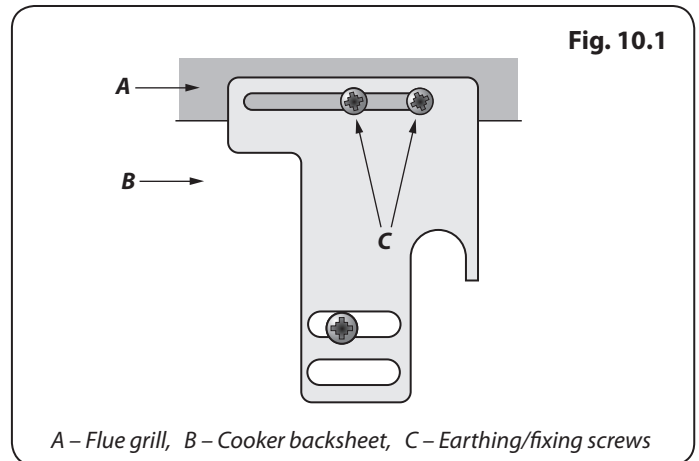

2 Hotplate

⚠ BEFORE SERVICING ANY GAS CARRYING COMPONENTS, TURN OFF THE GAS SUPPLY.

2.1 To Remove the Hotplate

Pull the cooker forward to gain access to the rear.

Left-hand tray

From the rear remove the screws securing the flue grill to the hotplate tray. Remove pan supports, burner heads and caps. Remove the 4 screws and washers holding the hotplate tray to the frame. Raise the front of the hotplate then withdraw.

Right-hand tray

From the rear remove the screws securing the flue grill to the hotplate tray. If the left-hand hotplate has not been removed, slacken the screws holding the left-hand tray. Remove the pan support, burner head, caps and trim rings. Remove the screws holding the wok burner to the hotplate. Remove the 2 screws and washers holding the right-hand tray to the frame.

Press the wok burner down slightly and, taking care not to damage the wok burner electrode, slide the tray about 30 mm to right to clear the locating brackets on the right-hand side and withdraw the hotplate.

Reassemble in reverse order. When replacing the right-hand hotplate take care not to damage the ignition electrode of the wok burner.

It is important that the rear fixing screws are refitted as they from part of the cooker earthing.

It is important that the rear fixing screws are refitted as they from part of the cooker earthing.

On some models there is a separate plate (**Fig. 10.1**). On others it is a tag on the cooker backsheet (**Fig. 10.2**).

It is important that the tag is on the outside and that both fixing screws are fitted.

Check for correct burner operation.

2.2 To Replace the Hotplate Control Taps

DISCONNECT FROM THE ELECTRICITY SUPPLY.

⚠ BEFORE SERVICING ANY GAS CARRYING COMPONENTS, TURN OFF THE GAS SUPPLY.

Remove the control panel and hotplate (see 1.1 & 2.1). Unplug the FSD lead from the rear of the tap. Undo the compression fitting at the rear of the tap and remove the fixings that secure the tap to the gas rail. Disconnect the ignition switch wiring.

Remove the tap. Remove and discard the gasket seal. Fit the new gasket seal to the replacement tap. Reassemble in reverse order. Check that the appliance is gas sound. Verify the hotplate ignition.

2.3 To Change a Hotplate Burner Injector

Remove the burner cap and head. Remove the old injector.

Fit the new injector. Reassemble in reverse order. Check the appliance is gas sound.

2.4 To Replace a Hotplate Burner Electrode

DISCONNECT FROM THE ELECTRICITY SUPPLY.

Lift off pan supports and remove the burner cap. Remove the screw holding the electrode. Pull the electrode vertically up sufficiently to grip the lead between thumb and forefinger.

Pull off the electrode, but keep hold of the lead. Fit the new electrode to the lead. Fix the electrode in the burner with screw. Replace the burner cap.

Check the burner ignition. Replace the pan supports.

2.5 To Replace a Hotplate Burner

DISCONNECT FROM THE ELECTRICITY SUPPLY.

Remove the hotplate tray (see 2.1). The burners (except the right-hand wok burner) are mounted on support struts. For these burners, disconnect the burner feed pipes at the burner. Remove the screws at the front and rear holding the support struts. Lift the strut and burners clear. The burners are fixed to the support struts with 2 screws. Remove the appropriate burner and fit the new one.

Reassemble in reverse order. Check that the burner operation is satisfactory.

Right-hand Wok Burner

Disconnect the burner feed pipes at the burner.

Fit the new one and reassemble in reverse order. Check that the burner operation is satisfactory.

2.6 To Change a Hotplate Burner Thermocouple

DISCONNECT FROM THE ELECTRICITY SUPPLY.

Remove the control panel and hotplate (see 1.1 & 2.1).

Unplug the FSD lead from the rear of the tap.

The thermocouple sits in a hole that has a slot at one side. Ensure that the thermocouple is cool. Turn the thermocouple so that the earth lead (no sleeve) is in line with the slot. Lift the thermocouple clear of the hole.

Reassemble in reverse order.

3 Controls

3.1. To Replace the Ignition or Light Switch

DISCONNECT FROM THE ELECTRICITY SUPPLY.

Remove the control panel (see 1.1).

Note: The old switch may be destroyed during removal. Remove the old switch from its bezel by gripping the switch body behind the control panel and twisting sharply. Remove the switch bezel by folding back the locking wings and pushing forward.

To fit the new bezel to the control panel: first line up the raised key on its body with the cut-out in the control panel and push it in from the front.

Assemble the new switch to the bezel by lining up the key sections and pushing home. Fit the new button by pushing in from the front.

Replace the control panel in the reverse order and test for correct operation.

3.2 To Replace the Clock

DISCONNECT FROM THE ELECTRICITY SUPPLY.

Remove the control panel (see 1.1). Pull off the timer control buttons.

Undo the timer fixing screws and remove the timer/mounting bracket assembly from the control panel.

Remove the timer from its mounting bracket by depressing the plastic lugs on the timer case, and at the same time pulling the unit forward.

Reassemble in reverse order. When replacing the leads, refer to the wiring diagram. Check the operation of the timer.

3.3 To Change the Ignition Generator

DISCONNECT FROM THE ELECTRICITY SUPPLY.

Pull the cooker forwards to gain access to the cover box at the rear of the cooker. Remove the screws securing the cover and lift clear. Pull off all the leads to the generator noting their positions. Slacken the 2 screws holding generator to cooker and remove the generator.

Fit the new generator to the cooker and replace the leads. Refer to the wiring diagram and reassemble in reverse order. Check ignition performance.

4 Grill

4.1 To Replace the Grill Controller

DISCONNECT FROM THE ELECTRICITY SUPPLY.

Remove the control panel and hotplate (see 1.1 & 2.1). Disconnect the wiring from controller. Remove the 2 screws holding the controller to the mounting panel.

Fit the new controller and reassemble in the reverse order. Check for correct operation.

4.2 To Replace the Grill Element

DISCONNECT FROM THE ELECTRICITY SUPPLY.

Remove the grill pan from the grill chamber. From inside the grill compartment, undo the 2 screws and washers and remove the enamelled front shield from the grill roof. Remove 2 screws and washers securing the grill element front support. Remove the screws from the grill elements.

Carefully lift the elements out and disconnect the leads from the element terminals, noting their position.

If it is not possible to disconnect the leads in this way, pull cooker forwards to gain access to the rear.

Remove the screws securing the electric cover to the back sheet, and then remove cover and disconnect the terminals from the rear.

Fit the new elements and reassemble in reverse order. Check the operation of the grill.

5 Ovens

5.1 To Remove the Oven Inner Back

Main Oven

Open the main oven door. Remove the 4 screws and washers securing the inner back to the back of the oven (**Fig. 10.3**). Carefully lift away the inner back.

Reassemble in reverse order, making sure that you fully tighten the 4 screws and washers.

Tall Oven

Open the tall oven door and remove the 2 screws and washers securing the inner back to the back of the oven. Carefully lift away the inner back.

Reassemble in reverse order.

Check the door for correct operation.

5.2 To Change the Oven Fan

DISCONNECT FROM THE ELECTRICITY SUPPLY.

Pull the cooker forward to gain access to the rear. Remove the screws securing the electric cover to the back sheet and remove the cover. Disconnect the 3 terminals connected to the fan, noting their position.

Remove the oven inner back (see 5.1). Hold the fan blade and remove the centre nut (left-hand thread), 2 brass washers, fan blade and circlip. Unscrew the fan retaining nuts and washers (3 off each) and lift the fan away from the rear of the cooker.

WARNING – SERVICING TO BE CARRIED OUT ONLY BY AN AUTHORISED PERSON
Disconnect from electricity before servicing. Check appliance is safe when you have finished.

Fig. 10.3

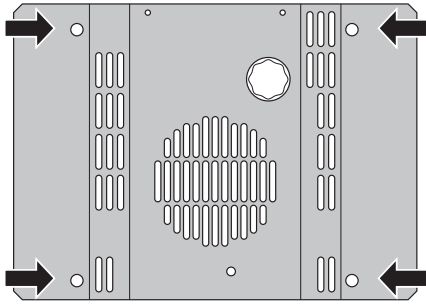
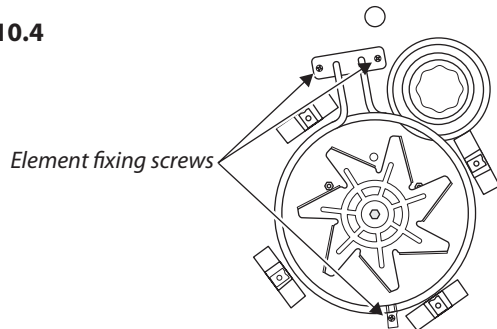

Fig. 10.4



Fit the new fan and reassemble in reverse order. Check the operation of the oven.

5.3 To Change the Oven Element

DISCONNECT FROM THE ELECTRICITY SUPPLY.

Remove the oven inner back (see 5.1).

Remove the 2 screws from the top of the element and the 1 from the bottom of the element (**Fig. 10.4**).

Carefully lift the element out, disconnecting the terminals connected to the element (noting their positions).

If it is not possible to disconnect the leads in this way, pull the cooker forward to gain access to the rear, remove the screws securing the electric cover to the back sheet, remove the cover and disconnect the terminals from the rear.

Fit the new element and reassemble in reverse order. Check the operation of the oven.

5.4 To Change an Oven Element Thermal Cut-out

DISCONNECT FROM THE ELECTRICITY SUPPLY.

Pull the cooker forwards to gain access to the cover box. Undo the cover screws and lift clear. The cut-out is located on the earth plate beside the oven element connections. Disconnect the cut-out wiring. Undo the fixings that secure the cut-out to the earth plate and remove.

Fit the replacement control and re-assemble in reverse order.

5.5 To Replace an Oven Thermostat

DISCONNECT FROM THE ELECTRICITY SUPPLY.

Remove the control panel and hotplate (see 1.1 & 2.1). Open the oven door and remove the oven furniture.

Main Oven

Remove the thermostat phial cover (2 screws). Unclip the thermostat phial from the clips in the oven back. For the left-hand oven, pull cooker forward to gain access to the cover box at the rear of the cooker. Remove the 4 screws securing the cover and lift clear.

Feed the thermostat capillary out of the oven. Disconnect the wiring from the thermostat. Remove 2 screws holding thermostat to mounting panel. Fit new thermostat and reassemble in reverse order. Make sure that the phial is clipped to the oven back with the phial centrally positioned between the clips.

Check the operation of the thermostat.

Tall Oven

Remove the oven inner back fixing screws and remove the inner back. Unclip the thermostat phial from the clips on the oven back. From the top pull the thermostat capillary up and out. Disconnect the leads and remove the thermostat and phial. Reassemble in reverse order.

Check the operation of thermostat.

WARNING – SERVICING TO BE CARRIED OUT ONLY BY AN AUTHORISED PERSON
Disconnect from electricity before servicing. Check appliance is safe when you have finished.

6 Doors

6.1 To Remove the Grill Door

Remove the left-hand side panel (see 1.2). Remove the plinth (4 screws) and the central vertical cover (5 screws). Remove the 2 countersunk screws (1 each side) securing the grill hinge arms to the front of the grill chamber.

Note: The arms are spring tensioned. Carefully remove the grill door. Retain the gaskets.

Reassemble in reverse order, making sure that the gasket is fitted between the hinge arm and the front of the grill chamber.

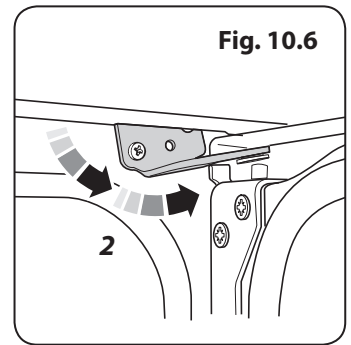
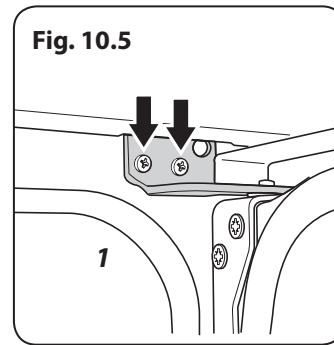

6.2 To Replace the Main Oven Door

Open the oven door. Support the door and loosen the 2 screws securing the upper hinge and gasket to the cooker front (Fig.9-6).

⚠ The door is heavy, so take care.

Support the door and remove the screw nearest the hinge pin (Fig. 10.6). Swing the hinge up and away from the door hinge pin. Lift the door away from the lower hinge and remove.

Reassemble in reverse order.

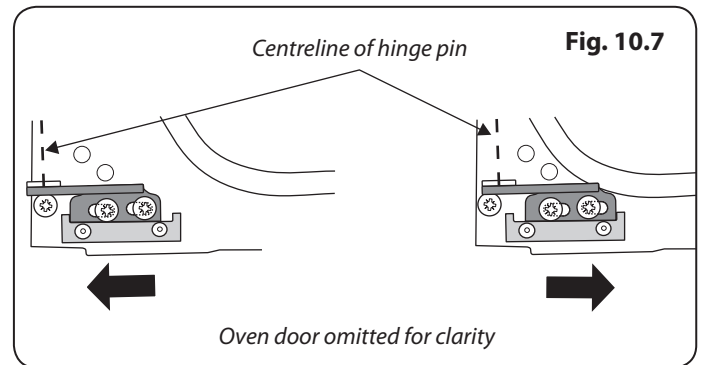

6.3 To Adjust the Main Oven Door Angle

The bottom hinge of the main oven door can be adjusted to alter the angle of the door (Fig. 10.7). Loosen the bottom hinge fixing screws and use the notch and a flat bladed screwdriver to move the position of the hinge to set the hinge position (Fig. 10.8).

Retighten the hinge screws.

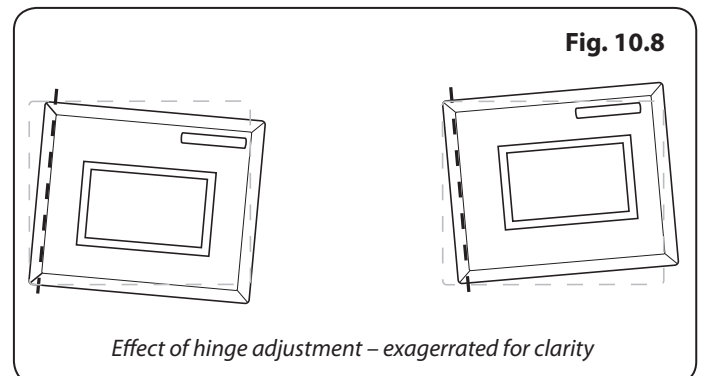

6.4 To Replace the Main Oven Door Outer Panel

Move the cooker forwards to gain access to the sides.

Open the main oven door slightly and remove the 4 front panel fixing screws from the door sides (2 each side), (Fig. 10.9). Carefully lift off the outer door panel.

Remove the door handle from the panel by unscrewing the 2 retaining nuts.

Fit the door handle to the new panel.

Fit the panel to the door. Reassemble in the reverse order.

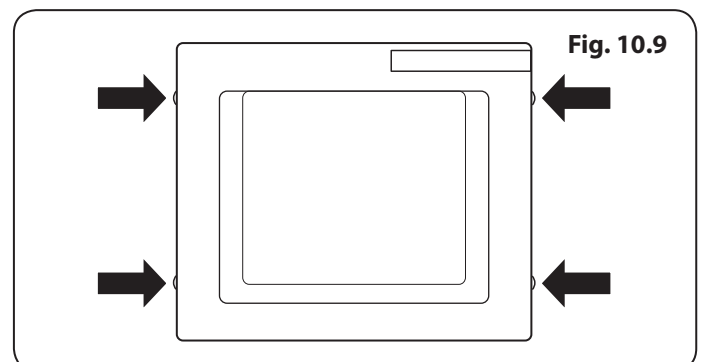

6.5 To Change the Main Oven Door Latch

Remove the main outer door panel (see 6.4). Remove screws 'B', which hold the latch assembly to the inner door panel (Fig. 10.10). Fit the new catch and reassemble in reverse order. Check the door operation.

6.6 To Adjust the Main Oven Door Catch Keep

Open the main oven door, slacken off the locknut at the base of the keep, and screw in or out as required until the required fit is obtained. Retighten the locking nut (Fig. 10.11).

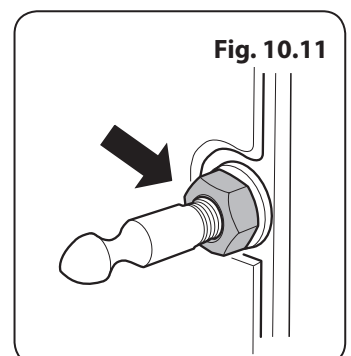
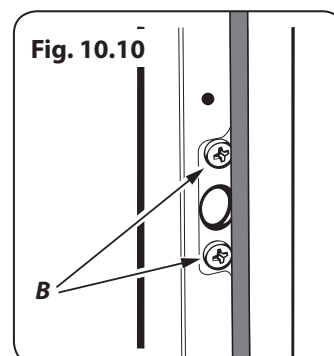

WARNING – SERVICING TO BE CARRIED OUT ONLY BY AN AUTHORISED PERSON
Disconnect from electricity before servicing. Check appliance is safe when you have finished.

Fig. 10.12

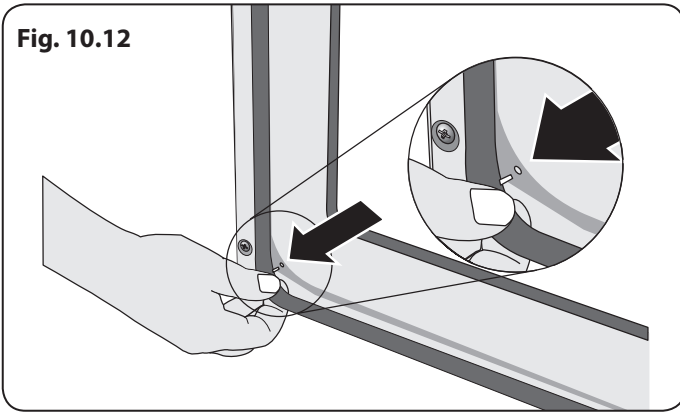

6.7 To Remove the Tall Oven Door

Open the oven door. Supporting the door, remove the 2 screws securing the upper hinge and packing to the cooker front. Remove the door from the lower hinge by lifting slightly and moving outwards.

Reassemble in reverse order.

6.8 To Replace the Tall Oven Door Outer Panel

Remove the tall oven door (see 6.7). Lay the door face down on a suitable surface and remove the 2 screws from bottom edge of door and the 2 screws from the inside face of the door.

Remove the outer door panel. Remove the door handle by unscrewing the 2 screws.

Remove the 2 cross-headed screws holding the door handle fixing bracket to the door panel. Fit the door handle bracket and the door handle to the new panel.

Fit the panel to the door and reassemble in reverse order.

6.9 To Replace the Tall Oven Door Magnetic Latch

Remove the control panel (see 1.1). Remove the plinth (3 screws) and the central vertical cover (5 screws). Lever the retaining clip off the magnet unit.

Fit the new unit and retaining clip, and reassemble in reverse order. Check the door operation.

6.10 To Change an Oven Door Seal

Open the oven door. The seal is held in place by small hooks on the rear face. At the corner, pull the seal diagonally away from the door centre until that hook is released (**Fig. 10.12**). Proceed to the next hook and release it in a similar way, and so on. Use force if the hooks are stiff, as the old seal will be discarded.

When fitting the new seal, position the seal join at the bottom. Hook the new seal in one of the corner holes of the door, and proceed round the door, snapping in each hook in turn.

6.11 Oven Door Glass

The glass on the oven doors is not replaceable.

11. Circuit Diagram

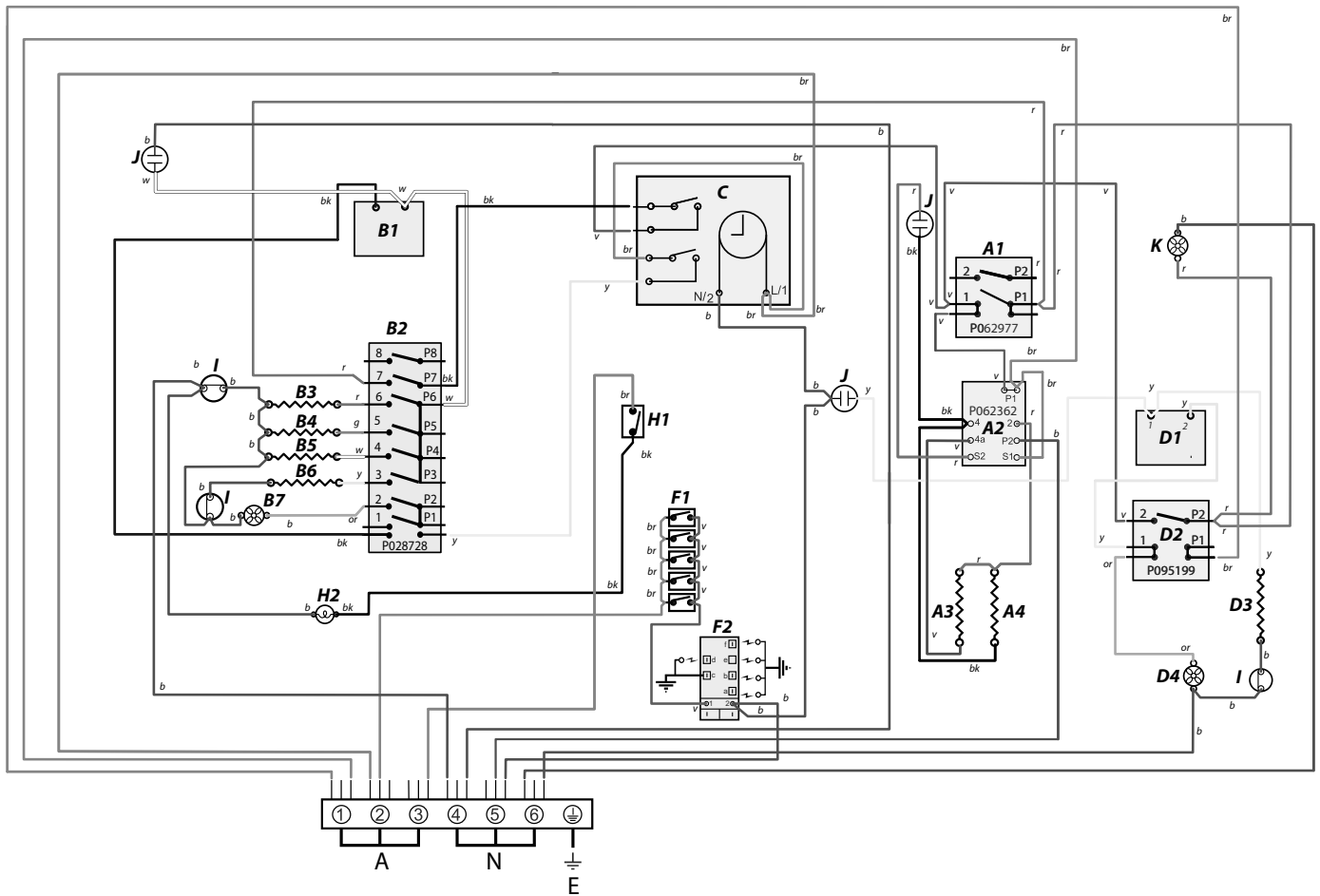

Key

The connections shown in the circuit diagram are for single-phase. The ratings are for 230 V 50 Hz.

Key	Description
A1	Grill front switch
A2	Grill energy regulator
A3	Grill element left-hand side
A4	Grill element right-hand side
B1	Left-hand multi-function oven thermostat
B2	Left-hand multi-function oven control
B3	Left-hand multi-function oven base element
B4	Left-hand multi-function oven top element (outer pair)
B5	Left-hand multi-function oven browning element (inner pair)
B6	Left-hand multi-function oven fan element
B7	Left-hand multi-function oven fan
C	Clock
D1	Right-hand fan oven thermostat
D2	Right-hand fan oven control
D3	Right-hand fan oven element
D4	Right-hand oven fan

Key	Description
F1	Ignition switches
F2	Ignition spark generator
H1	Oven light switch
H2	Oven light
I	Thermal cut-out
J	Neon
K	Cooling Fan

Code	Colour
b	Blue
br	Brown
bk	Black
or	Orange
r	Red
v	Violet
w	White
y	Yellow
g/y	Green/Yellow
gr	Grey

12. Technical Data

THE COOKER IS CATEGORY: CatII₂H3+.

It is supplied set for group H natural gas. A conversion kit from NG to LP is available for the cooker.

INSTALLER: Please leave these instructions with the user.

DATA BADGE LOCATION: Cooker back, serial number repeater badge below oven door opening.

COUNTRY OF DESTINATION: Australia.

Pressures

Gas (Rp ½ at rear right-hand side)		Electric
Supply Pressure at the inlet to appliance regulator		230/400V 50 Hz
Natural Gas	1.13 kPa	
Propane	2.75 kPa	
Operating Pressure at appliance test point		
Natural Gas	1 kPa	
Propane	2.54 kPa	

See the appliance badge for test pressures.

Dimensions

Model	NEXUS 90 Dual Fuel	
Overall height	minimum 905 mm	maximum 930 mm
Overall width	900 mm	
Overall depth	608 mm excluding handles, 648 mm including handles	
Minimum height above the hotplate	650 mm	

Hotplate Ratings

BSI Evo 1 Type Burners Australia			
Burner Type	Input Rate MJ/Hr		Bypass Screw
	Natural Gas	Propane X	
Wok	15.2	15.0	55 **
Rapide	12.3	12.0	41 **
Semi Rapide	6.2	6.2	33 **
Auxillary	3.7	3.3	25 **

** The valves in this cooker are fitted with adjustable bypass screws. The cooker is supplied with the bypass screws set for Natural Gas. For LPG conversion the bypass screws must be screwed all the way down.

Hotplate energy saving tips

- Use cookware with a flat base.
- Use the correct size cookware.
- Use cookware with a lid.
- Minimise the amount of liquid or fat.
- When liquid starts boiling, reduce the setting.
- Consumption is based on G30.

Oven energy saving tips

- Cook meals together, if possible.
- Keep the pre-heating time short.
- Do not lengthen cooking time.
- Do not open the oven door during the cooking period.
- Do not forget to turn the appliance off at the end of cooking.

Hotplate Efficiency

Brand	Falcon
Model Identification	Nexus
Size	90
Type	Dual Fuel

Type of Hob	GAS
Number of gas burners	5
Auxiliary / Small Burner (EE gas burner)	-
Semi Rapide / Medium Burner (EE gas burner)	58%
Semi Rapide / Medium Burner (EE gas burner)	58%
Rapide / Large Burner (EE gas burner)	56%
Rapide / Large Burner (EE gas burner)	-
Wok (EE gas burner)	53%
Wok (EE gas burner)	-
Hotplate EE gas hob (*)	56%

Information marked thus (*) is not required with mixed fuel hobs

Oven Data

Brand		Falcon
Model identification		Nexus
Type of oven		Electric
Mass	kg	112
Number of cavities		2
Left-hand Efficiency		
Fuel type		Electric
Cavity type		Multifunction
Power - conventional		2.2
Power - forced air convection		2.5
Volume	Litres	73
Energy consumption (electricity) - conventional	kWh / cycle	1.08
Energy consumption (electricity) - forced air convection	kWh / cycle	0.91
Energy efficiency index - conventional		126.1
Energy efficiency index - forced air convection		106.2
Energy class		A
Right-hand Efficiency		
Fuel type		Electric
Cavity type		Fanned
Power - conventional		-
Power - forced air convection		2.5
Volume	Litres	67
Energy consumption (electricity) - conventional	kWh / cycle	-
Energy consumption (electricity) - forced air convection	kWh / cycle	0.8
Energy efficiency index - conventional		-
Energy efficiency index - forced air convection		96.2
Energy class		A

Additional Information		
The oven complies with EN 60350-1		
Maximum output @ 230V 50Hz		
Conventional		2.2 kW
Multifunction		2.5 kW
Multifunction (with Rapid Response)		-
Forced Air Convection		2.5 kW
Grill		2.3 kW
Slow Oven		-
Bread Proving Drawer		-

Maximum total electrical load at 230 V (approximate total including hob, oven lights, oven fan, etc.):	7.4 kW
---	--------

Note

Note

Note

AGA RANGEmaster

Clarence Street, Royal Leamington Spa,
Warwickshire, CV31 2AD, England.

Tel: +44 (0) 1926 457400 Fax: +44 (0) 1926 450526

E-mail: consumers@falconappliances.co.uk

